

# wilo Pump Data Sheet

Sheet No.	
Customer	
Item No.	
Date	2015-12-15

1	<b>MODEL</b>	Helix V411 / PN16		Title			
2	Location			Agent			
3	Service			Plant Name			
4	Quantity	Set(s)		Installation	<input checked="" type="checkbox"/> Indoor <input type="checkbox"/> Outdoor		
5	<b>OPERATING CONDITION</b>						
6	Liquid	Water		Flow	0 l/min		
7	Pumping Temp.	Ambient		Suc. Pressure			
8	S.G.	1		Dis. Pressure			
9	Vap. Pressure	1kg/cm2A		Diff. Pressure			
10	Viscosity	1 cP		Total Head	0 m		
11	<b>PERFORMANCE AND CONSTRUCTION</b>					<b>MATERIAL</b>	
12	Vertical		Efficiency	%		Part Name	Symbol
13	No. of Stages	11		Rated Power			
14	Speed	3550 rpm		NPSHre			
15	Rotation	CW (view from drive end)				Shaft	STS304
16	Bore	Size(Dia)	Rating	Face	Position	Tube	STS304
17	Suction	25 mm	PN 16	RF	Side	Diffuser	STS304L
18	Discharge	25 mm	PN 16	RF	Side	Top Cover	STS304
19	Impeller Type	Closed		Vertical Multi-Stage		<b>HYDROSTATIC</b>	
20	Flow Direction	Radial			Casing	3 min	
21	Shaft Seal	M/Seal	Shaft Sleeve	No	Jacket	3 min	
22	Mounting	Foot			<b>TESTING</b>		
23	Lubrication	<input checked="" type="checkbox"/> Grease			Items	Witness	
24	Cooling	<input checked="" type="checkbox"/> No Cooling			Run Perform.	<input checked="" type="checkbox"/> Yes <input type="checkbox"/> No	<input type="checkbox"/> Yes <input checked="" type="checkbox"/> No
25	Radial Bearing	-	Thrust Bearing	-	Hydrostatic(Air Press.)	<input checked="" type="checkbox"/> Yes <input type="checkbox"/> No	<input type="checkbox"/> Yes <input checked="" type="checkbox"/> No
26	<b>MOTOR SPECIFICATION</b>					<b>SPARE PART</b>	
27	Supplier	WILO		Phase / V / Hz	3~ 380V ~ 60 Hz		Set(s)
28	Type	TEFC		Furnished by	<input checked="" type="checkbox"/> WILO <input type="checkbox"/> Customer		Set(s)
29	Power	3 kW		Mounted by	<input checked="" type="checkbox"/> WILO <input type="checkbox"/> Customer		Set(s)
30	No. of Pole	2 P		Enclosure	<input checked="" type="checkbox"/> IP 55 <input type="checkbox"/>		Set(s)
31	Insulation	<input checked="" type="checkbox"/> F <input type="checkbox"/>					Set(s)
32	<b>ACCESSORY(<input checked="" type="checkbox"/>Supplied : WILO)</b>					Set(s)	
33	<input type="checkbox"/> Common Base					Set(s)	
34	<input type="checkbox"/> Foundation Bolts & Nuts					Set(s)	
35	<input checked="" type="checkbox"/> Coupling	Half (Rigid & Split Type)		<input checked="" type="checkbox"/> Coupling Guard		Set(s)	
36	<input type="checkbox"/> Pressure Guage					Set(s)	
37	<input checked="" type="checkbox"/> Plug for Drain & Air vent.					Set(s)	
38	<input type="checkbox"/> Seal Flushing					Set(s)	
39	M/Seal	Maker	Eagle-Burgmann	Model & Size	MG12		Set(s)
40		Type	Unbalanced	Cooler	<input type="checkbox"/> Yes <input checked="" type="checkbox"/> No		Set(s)
41		API 610 Plan					<b>WEIGHT</b>
42		Material Code	SiC/Carbon,EPDM			Pump	49 kg
43	<input type="checkbox"/> Companion Flanges						
44	<input type="checkbox"/> Special Tool						
						Total wt.	49 kg

# Estimated Performance Curve

Sheet No.	
Customer	
Item No.	
Date	2015-12-15

## SPECIFICATION

PUMP		MOTOR	
CAPACITY	0 l/min	OUTPUT	3 kW
TOTAL HEAD	0 m	VOLTAGE	380V
SUCTION BORE	25 mm	FREQUENCY	60 Hz
DISCHARGE BORE	25 mm	SPEED	3550 1/min
LIQUID	WATER	TYPE	TEFC
MAKER	WILO	SUPPLIER	WILO

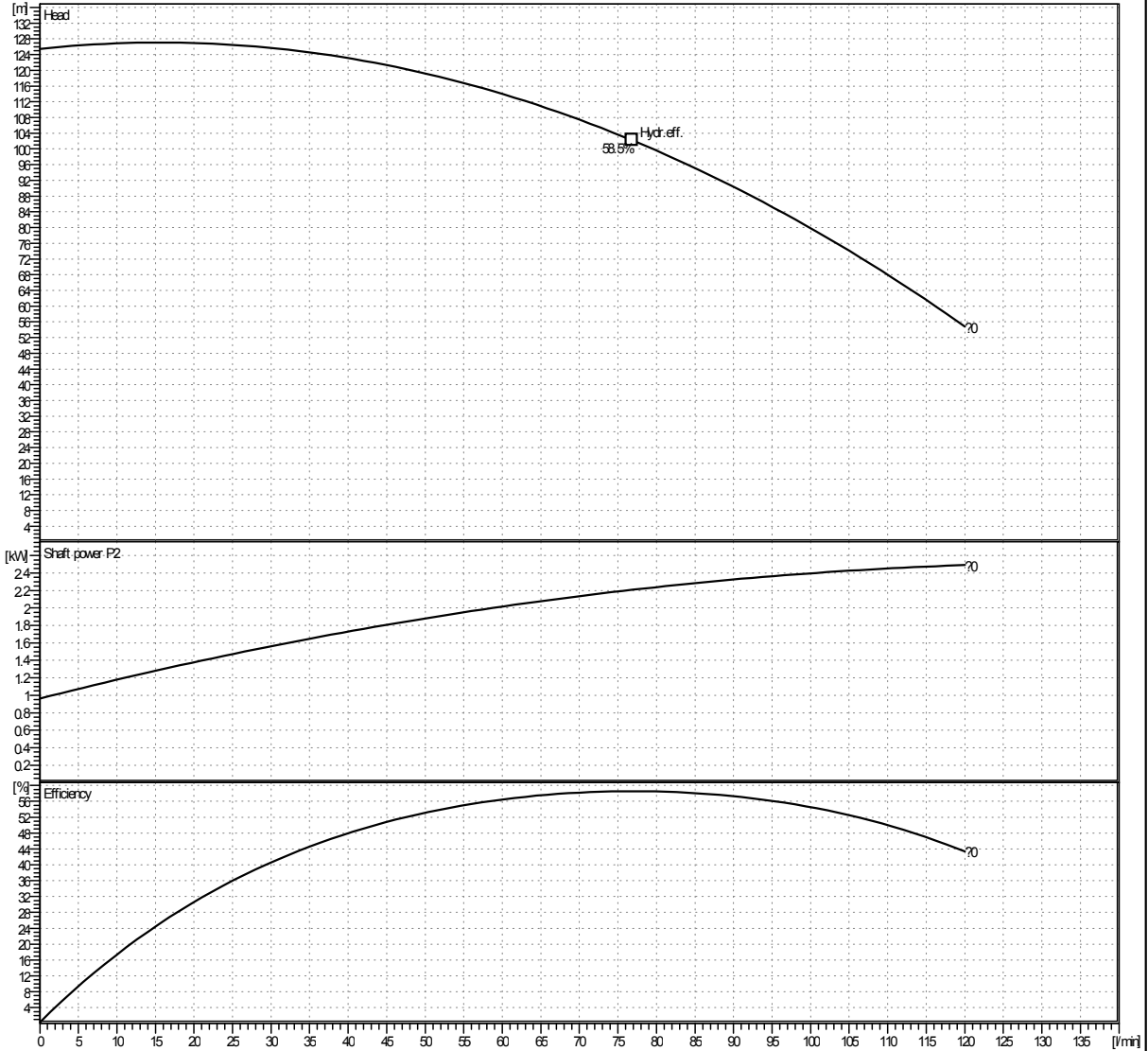

A/B Efficiency	Capacity	Efficiency(%)
A Efficiency	76.88 l/min	58.5
B Efficiency		

\* Performance curve of some models is subject to have 10% deviation.

\* Subject to change without prior notice.

TYPE	Vertical Multi-Stage
MODEL	Helix V411 / PN16
SERVICE	

# Outline Drawing

Sheet No.	
Customer	
Item No.	
Date	2015-12-15

## SPECIFICATION

<b>PUMP</b>	CAPACITY	0 l/min	<b>MOTOR</b>	OUTPUT	3 kW
	TOTAL HEAD	0 m		VOLTAGE	380V
	SUCTION BORE	25 mm		FREQUENCY	60 Hz
	DISCHARGE BORE	25 mm		SPEED	3550 1/min
	LIQUID	WATER		TYPE	TEFC
	MAKER	WILO		SUPPLIER	WILO

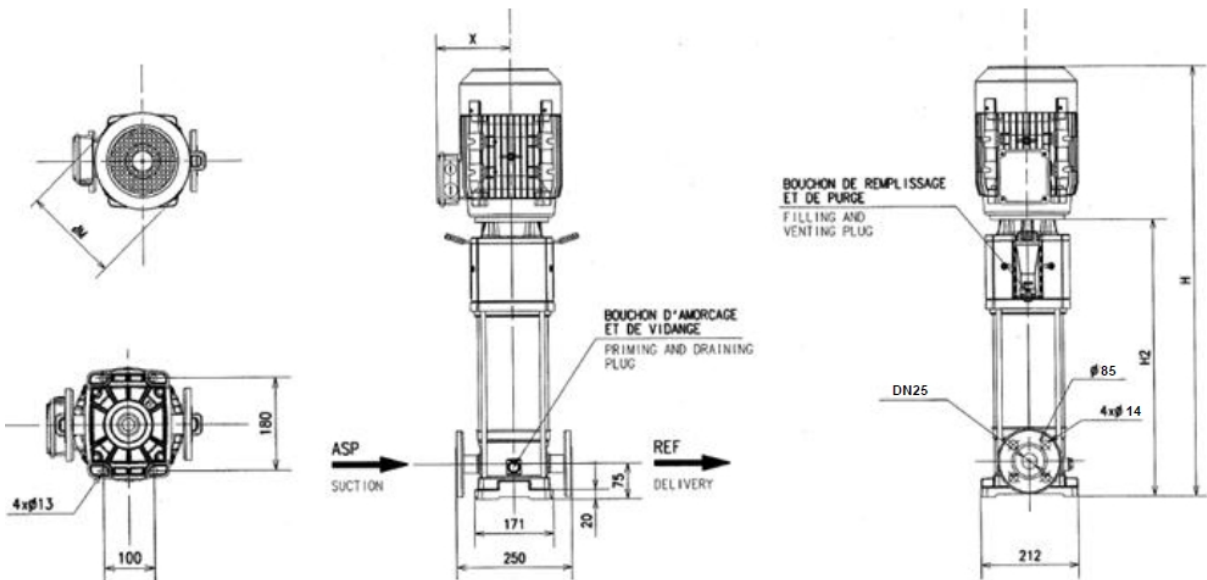

H	968	H2	641	M	195	X	148
---	-----	----	-----	---	-----	---	-----

TYPE	Vertical Multi-Stage
MODEL	Helix V411 / PN16
SERVICE	

# Sectional Drawing

Sheet No.	
Customer	
Item No.	
Date	2015-12-15

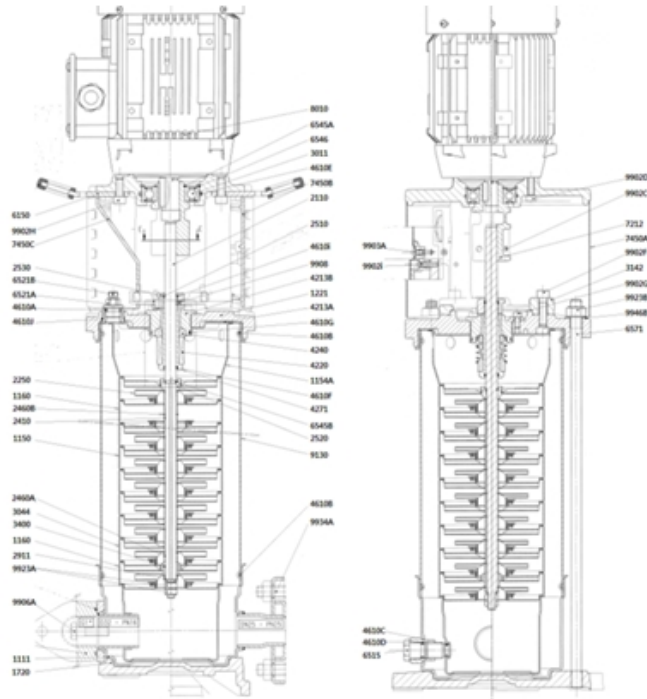

No.	Description	No.	Description	No.	Description
1111	Pump casing	8010	Motor	7450A	Sheet coupling protector
1150	Stage casing with return guide vane serial 4	9130	Tube	7450	Coupling guard support
1154A	Discharge chamber with return guide vane serial 4	9908	Screw	9902C	Screw for coupling
1160	Stage casing without return guide vane serial 4	2460A	Sleeve spacer	9902D	Screw fix. motor
1221	End shield	2460B	Flat washer	9902F	Screw fix. lantern/end shield
1720	Base	3400	Shaft sleeve	9902G	Screw
2110	Pump shaft	4213A	Assembled ring cover of mechanical seal	9902H	Srew fix. Platinize handling
2250	Impeller M=4	4213B	Mechanical seal ø18 ring holder	9902I	Plastic support screw
2410	Spacer	4220	Rotating part-mechanical seal	9906A	Screw
2510	Setting shim shaft	4240	Stationary part-mechanical seal	9923A	Shaft end nut
2520	Back-up ring(or Thrust ring)	4610A	O'ring for filling and venting plug	9923B	Nut for tie bolt
2530	Drive ring for mechanical seal	4610B	O'ring	9934A	Bolt
2911	Shaft end washer	4610C	O'ring drain and priming plug	9946B	Washer under 9923B nut
3011	Lantern ball bearing	4610D	O'ring drain and priming plug	No.	Description
3044	Bearing stage casing with return guide vane serial 4	4610E	O'ring for ball bearing	2472	Hub
3142	Lantern	4610F	O'ring	6548	Stop-rush
4271	Shaft sleeve	4610G	O'ring	7021	Spacer
6150	Platinize handling	4610I	O'ring	7212	Coupling
6515	Drain and priming plug	4610J	O'ring	9902J	Screw for spacer
6521	Filling and venting plug	4610K	O'ring	9906E	Screw fix. motor
6546	Circlip(lantern ball bearing)	6545A	Circlip shaft for ball bearing	9923C	Nut for fixing motor
6571	Tie bolt	6545B	Half keeper(thrust ring)		

TYPE	Vertical Multi-Stage
MODEL	Helix V411 / PN16
SERVICE	

# Sectional Drawing

Sheet No.	
Customer	
Item No.	
Date	2015-12-15

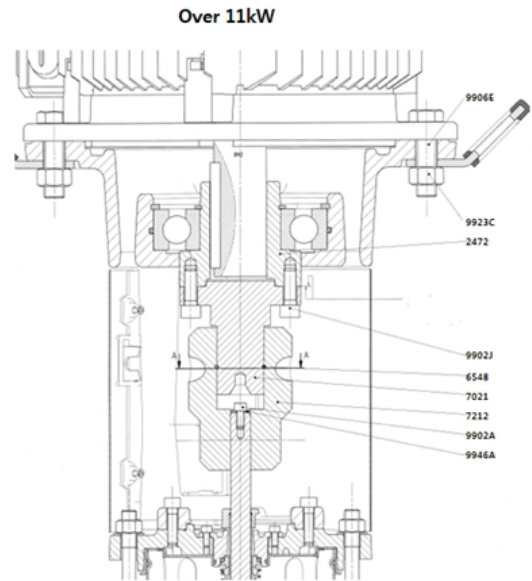
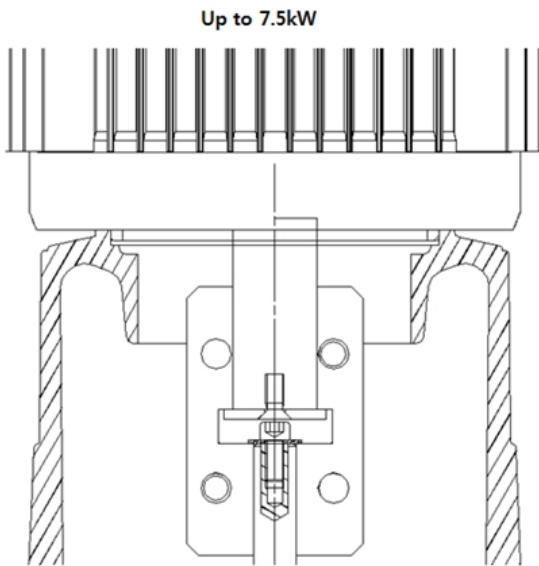

No.	Description
9906E	Screw fix. Motor
9923C	Motor fastening nut
2472	Hub
9902J	Screw for spacer
6548	Stop-rush
7021	Spacer
7212	Coupling

TYPE	Vertical Multi-Stage
MODEL	Helix V411 / PN16
SERVICE	