

wilo Pump Data Sheet

Sheet No.	
Customer	
Item No.	
Date	2017-03-28

1	Model	PBI-405MA		Title	
2	Location			Agent	
3	Service			Plant Name	
4	Quantity	Set(s)	Installation	<input checked="" type="checkbox"/> Indoor	<input type="checkbox"/> Outdoor
5	OPERATING CONDITION				
6	Liquid	Water		Capacity	66 lpm
7	Pumping Temp.	0~40		Suct. Head	0 m
8	S.G	1		Disch. Head	60 m
9	Vap. Pressure	1kg/cm2A		Total head	60 m
10	Viscosity	1 cp			
11	PERFORMANCE AND CONSTRUCTIONS			MATERIAL	
12	Horizontal		Efficiency	%	
13	No. of Stages	5	Rated Power	2.2KW	
14	Speed	3450rpm	NPSHre	Shaft	STS316L
15	Rotation	CCW (view from drive end)		Casing	STS304
16	Bore	Size(Dia)	Rating	Face	Position
17	Suction	32 mm			Side
18	Discharge	25 mm			Top
19	Impeller Type	Closed	Single suction		HYDROSTATIC
20	Flow Direction	Radial		Casing	10 kgf/cm2 3 min
21	Shaft Seal	M/Seal	Shaft Sleeve	No	Pressure Tank 20 kgf/cm2 3 min
22	Mounting	Foot		TESTING	
23	Lubrication	<input checked="" type="checkbox"/> Grease	<input type="checkbox"/> Oil Bath		Items (Witness)
24	Cooling	<input type="checkbox"/> Stuff.Box	<input type="checkbox"/> B/R Housing	<input checked="" type="checkbox"/> No Cooling	Run Perform. <input checked="" type="checkbox"/> Yes <input type="checkbox"/> No <input type="checkbox"/> Yes <input checked="" type="checkbox"/> No
25	Pump Side	6304zz	Fan Side	6204zz	Hydrostatic <input checked="" type="checkbox"/> Yes <input type="checkbox"/> No <input type="checkbox"/> Yes <input checked="" type="checkbox"/> No
26	DRIVER SPECIFICATION			SPARE PARTS	
27	Maker	WILO	Phase / V / Hz	1 ~ 220V ~ 60Hz Set(s)	
28	Type	Induction Motor	Motor Frame No.	Set(s)	
29	Power	2.2KW	Furnished by	<input checked="" type="checkbox"/> WILO <input type="checkbox"/> Customer	Set(s)
30	Pole & Speed	2p 3450rpm	Mounted by	<input checked="" type="checkbox"/> WILO <input type="checkbox"/> Customer	Set(s)
31	Insulation	F	Protection	IP X4 Set(s)	
32	ACCESSORIES(<input checked="" type="checkbox"/>Supplied : WILO)			Set(s)	
33	<input type="checkbox"/> Common Base			Set(s)	
34	<input type="checkbox"/> Foundation Bolts & Nuts			Set(s)	
35	<input type="checkbox"/> Coupling	No	<input type="checkbox"/> Coupling Guard	Set(s)	
36	<input type="checkbox"/> Pressure Gauge			Set(s)	
37	<input type="checkbox"/> Collar or Plug for Drain & Air vent.			Set(s)	
38	<input type="checkbox"/> Seal Flushing			Set(s)	
39	M/Seal	Maker	Burgmann	Model & Size	14 Set(s)
40		Type	MG1/14-G606	Cooler	<input type="checkbox"/> Yes <input checked="" type="checkbox"/> No Set(s)
41				Set(s)	
42	<input type="checkbox"/> Companion Flanges			Weight	
43	<input type="checkbox"/> Special Tool				
44					
45				Total Wt.	15.5 kg

Estimated Performance Curve

Sheet No.	
Customer	
Item No.	
Date	2017-03-28

SPECIFICATION

PUMP	Capacity	66 lpm at	m	MOTOR	OUTPUT	2.2KW
	Total Head	60	m		VOLTAGE	220V
	SUCTION BORE	32	mm		FREQUENCY	60 Hz
	DISCHARGE BORE	25	mm		SPEED	3450 1/min
	LIQUID	WATER			TYPE	Induction Motor
	MAKER	WILO			MAKER	WILO

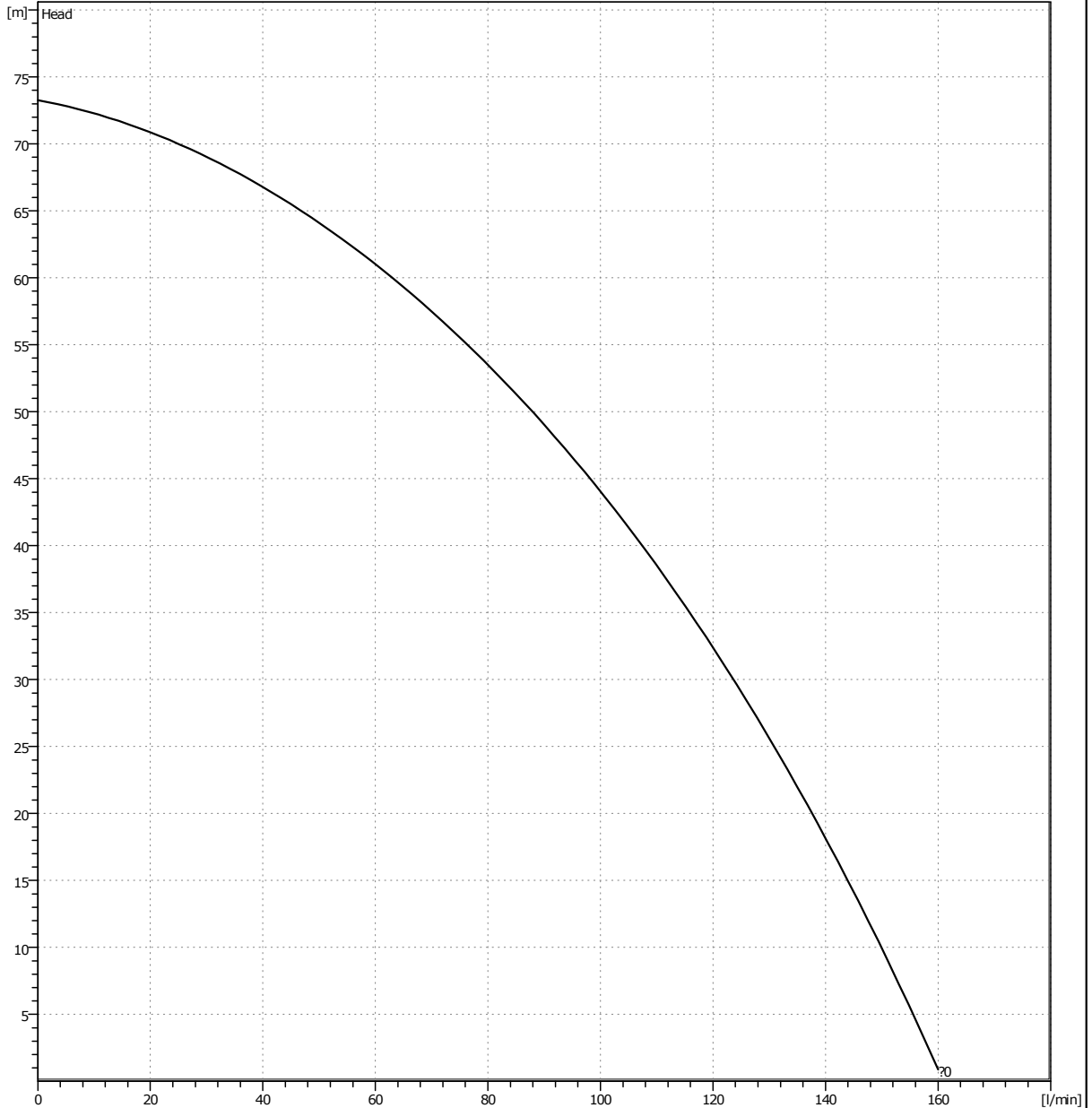

*Performance curve of some models is subject to have 10% deviation.

*Subject to change without prior notice.

TYPE	Muiti Stage Horizontal
MODEL	PBI-405MA
SERVICE	

Outline Drawing

Sheet No.	
Customer	
Item No.	
Date	2017-03-28

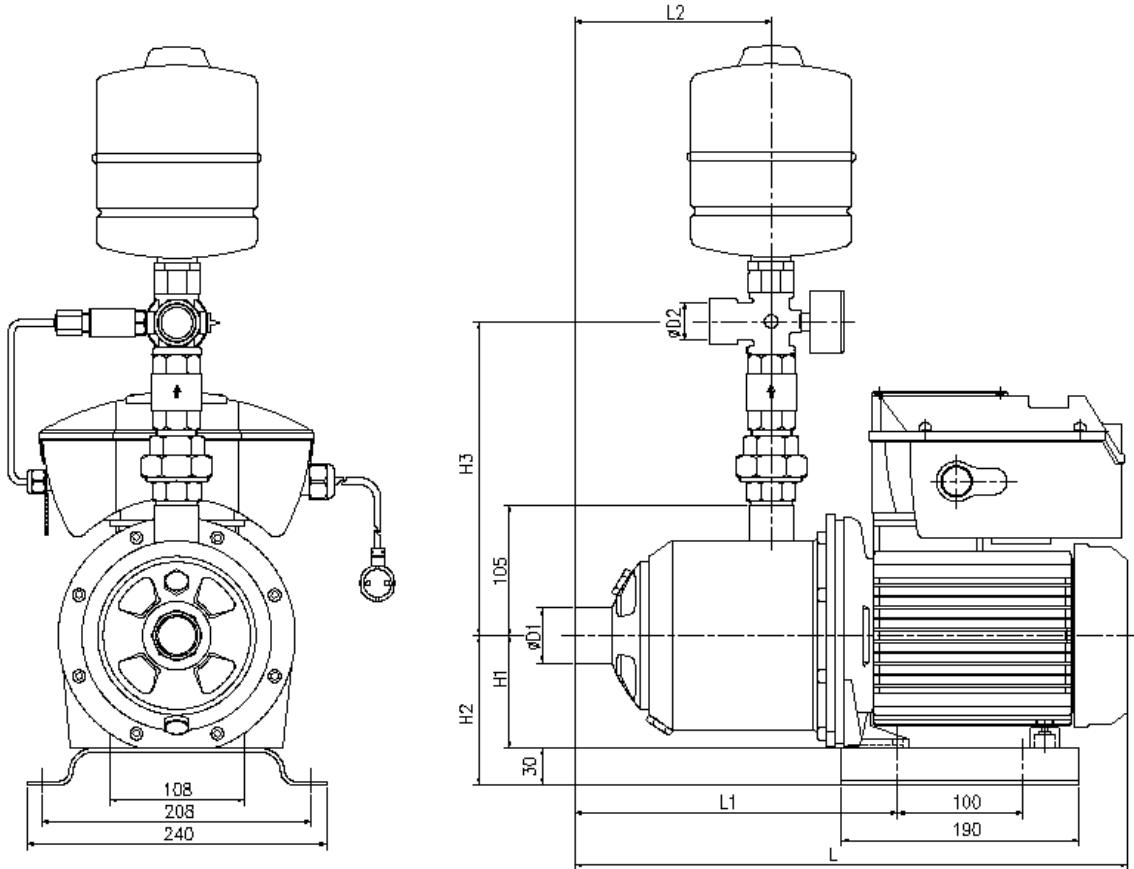

모델명	Dimension(mm)									
	H	H1	H2	H3	L	L1	L2	ΦD1	ΦD2	중량 (kg)
PBI-203MA	610	90	120	380	385	185	109.5	1"	1"	13
PBI-205MA	610	90	120	380	430	235	157.5	1"	1"	15
PBI-402MA	610	90	120	380	385	185	109.5	1 1/4"	1"	14
PBI-403MA	610	90	120	380	385	185	109.5	1 1/4"	1"	17
PBI-404MA	610	90	120	380	425	225	157.5	1 1/4"	1"	17
PBI-405MA	610	90	120	380	425	225	157.5	1 1/4"	1"	18
PBI-802MA	630	90	120	385	390	190	121.5	1 1/2"	1 1/4"	18
PBI-803MA	630	90	120	385	390	190	121.5	1 1/2"	1 1/4"	19

--	--	--	--	--	--	--	--	--	--	--	--

TYPE	Multi Stage Horizontal
MODEL	PBI-405MA
SERVICE	

Sectional Drawing

Sheet No.	
Customer	
Item No.	
Date	2017-03-28

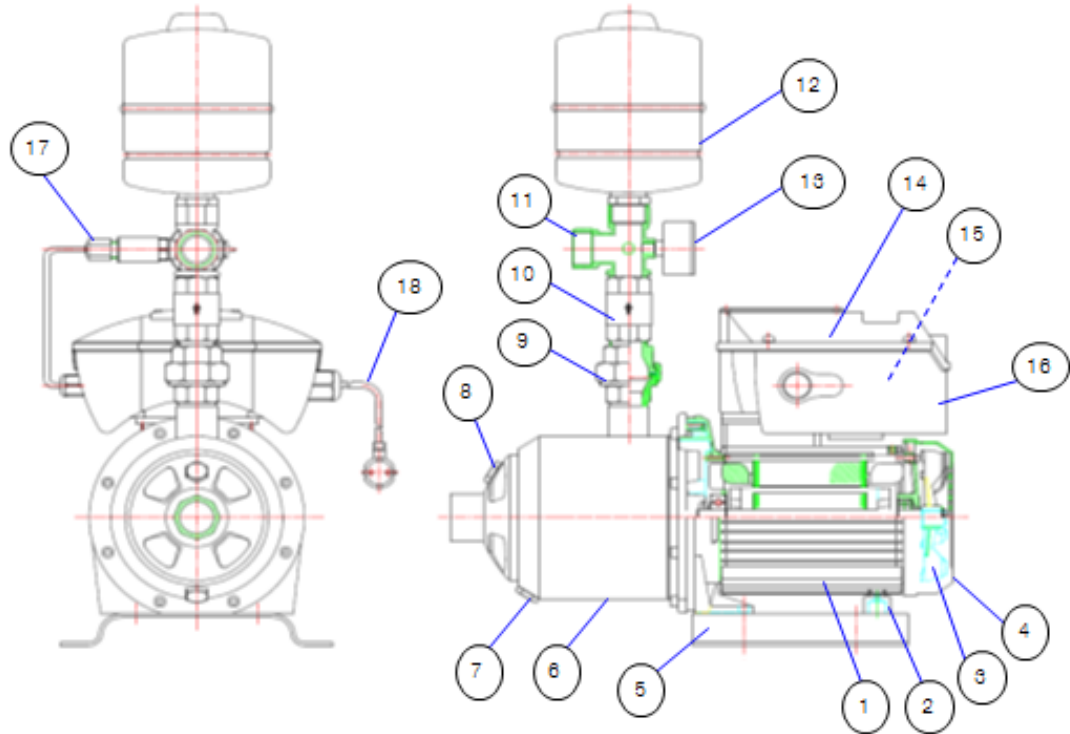

Cls.	Part Name	Specification	Quantity	Remarks
1	Motor Assembly	3phase 220V 60Hz	1	
2	Motor Supporter	ABS(HI-100)	1	
3	Fan	PBT(GP-2200)	1	
4	Fan Cover	SCP or ABS(HI-100)	1	
5	Base Plate	SCP	1	
6	Casing	STS304	1	
7	Drain Plug	STS316L	1	
8	Priming Plug	STS316L	1	
9	Union Assembly	Brass or STS304	1	
10	Check Valve	STS304	1	
11	Cross Nipple	Brass or STS304	1	
12	Pressure Tank	SCP/Rubber	1	
13	Pressure Gauge	16bar	1	
14	Inverter Cover	ABS(AF-305F)	1	
15	Inverter Assembly	-	1	
16	Inverter Base	ABS(AF-305F)	1	
17	Transmitter	16bar	1	
18	Power Cord	PNCT 3C	1	

TYPE	Muiti Stage Horizontal
MODEL	PBI-405MA
SERVICE	