

wilo Pump Data Sheet

| | |
|-----------|------------|
| Sheet No. | |
| Customer | |
| Item No. | |
| Date | 2017-03-28 |

| | | | | | |
|----|---|--|--------------------------------------|--|---|
| 1 | Model | PBI-406UA | | Title | |
| 2 | Location | | | Agent | |
| 3 | Service | | | Plant Name | |
| 4 | Quantity | Set(s) | Installation | <input checked="" type="checkbox"/> Indoor | <input type="checkbox"/> Outdoor |
| 5 | OPERATING CONDITION | | | | |
| 6 | Liquid | Water | | Capacity | 125 lpm (at Ht=60m) |
| 7 | Pumping Temp. | 0~40 | | Suct. Head | 0 m |
| 8 | S.G | 1 | | Disch. Head | 60 m |
| 9 | Vap. Pressure | 1kg/cm2A | | Total head | 60 m |
| 10 | Viscosity | 1 cp | | | |
| 11 | PERFORMANCE AND CONSTRUCTIONS | | | MATERIAL | |
| 12 | Horizontal | | Efficiency | % | |
| 13 | No. of Stages | 6 | Rated Power | 2.2KW | |
| 14 | Speed | 3450rpm | NPSHre | Shaft | |
| 15 | Rotation | CCW (view from drive end) | | Casing | STS304 |
| 16 | Bore | Size(Dia) | Rating | Face | Position |
| 17 | Suction | 32 mm | | | End |
| 18 | Discharge | 25 mm | | | Top |
| 19 | Impeller Type | Closed | Single suction | | HYDROSTATIC |
| 20 | Flow Direction | Radial | | Casing | 10 kgf/cm2 |
| 21 | Shaft Seal | M/Seal | Shaft Sleeve | No | Pressure Tank |
| 22 | Mounting | Foot | | TESTING | |
| 23 | Lubrication | <input checked="" type="checkbox"/> Grease | <input type="checkbox"/> Oil Bath | | Items |
| 24 | Cooling | <input type="checkbox"/> Stuff.Box | <input type="checkbox"/> B/R Housing | <input checked="" type="checkbox"/> No Cooling | Run Perform. |
| 25 | Pump Side | 6202zz | Fan Side | 6302zz | Hydrostatic |
| 26 | DRIVER SPECIFICATION | | | SPARE PARTS | |
| 27 | Maker | WILO | Phase / V / Hz | 3 ~ 380V ~ 60Hz | |
| 28 | Type | Induction Motor | Motor Frame No. | | |
| 29 | Power | 2.2KW | Furnished by | <input checked="" type="checkbox"/> WILO | <input type="checkbox"/> Customer |
| 30 | Pole & Speed | 2p 3450rpm | Mounted by | <input checked="" type="checkbox"/> WILO | <input type="checkbox"/> Customer |
| 31 | Insulation | F | Protection | IP X4 | |
| 32 | ACCESSORIES(<input checked="" type="checkbox"/>Supplied : WILO) | | | | |
| 33 | <input type="checkbox"/> Common Base | | | | |
| 34 | <input type="checkbox"/> Foundation Bolts & Nuts | | | | |
| 35 | <input type="checkbox"/> Coupling | No | | <input type="checkbox"/> Coupling Guard | |
| 36 | <input type="checkbox"/> Pressure Gauge | | | | |
| 37 | <input type="checkbox"/> Collar or Plug for Drain & Air vent. | | | | |
| 38 | <input type="checkbox"/> Seal Flushing | | | | |
| 39 | M/Seal | Maker | Burgmann | Model & Size | 14 |
| 40 | | Type | MG1/14-G606 | Cooler | <input type="checkbox"/> Yes <input checked="" type="checkbox"/> No |
| 41 | | | | | |
| 42 | <input type="checkbox"/> Companion Flanges | | | Weight | |
| 43 | <input type="checkbox"/> Special Tool | | | | |
| 44 | | | | | |
| 45 | | | | Total Wt. | 20 kg |

Estimated Performance Curve

| | |
|-----------|------------|
| Sheet No. | |
| Customer | |
| Item No. | |
| Date | 2017-03-28 |

SPECIFICATION

| | | | | | |
|-------------|----------------|----------------------|--------------|-----------|-----------------|
| PUMP | Capacity | 125 lpm (att Ht=60m) | MOTOR | OUTPUT | 2.2KW |
| | Total Head | 60 m | | VOLTAGE | 380V |
| | SUCTION BORE | 32 mm | | FREQUENCY | 60 Hz |
| | DISCHARGE BORE | 25 mm | | SPEED | 3550 1/min |
| | LIQUID | WATER | | TYPE | Induction Motor |
| | MAKER | WILO | | MAKER | WILO |

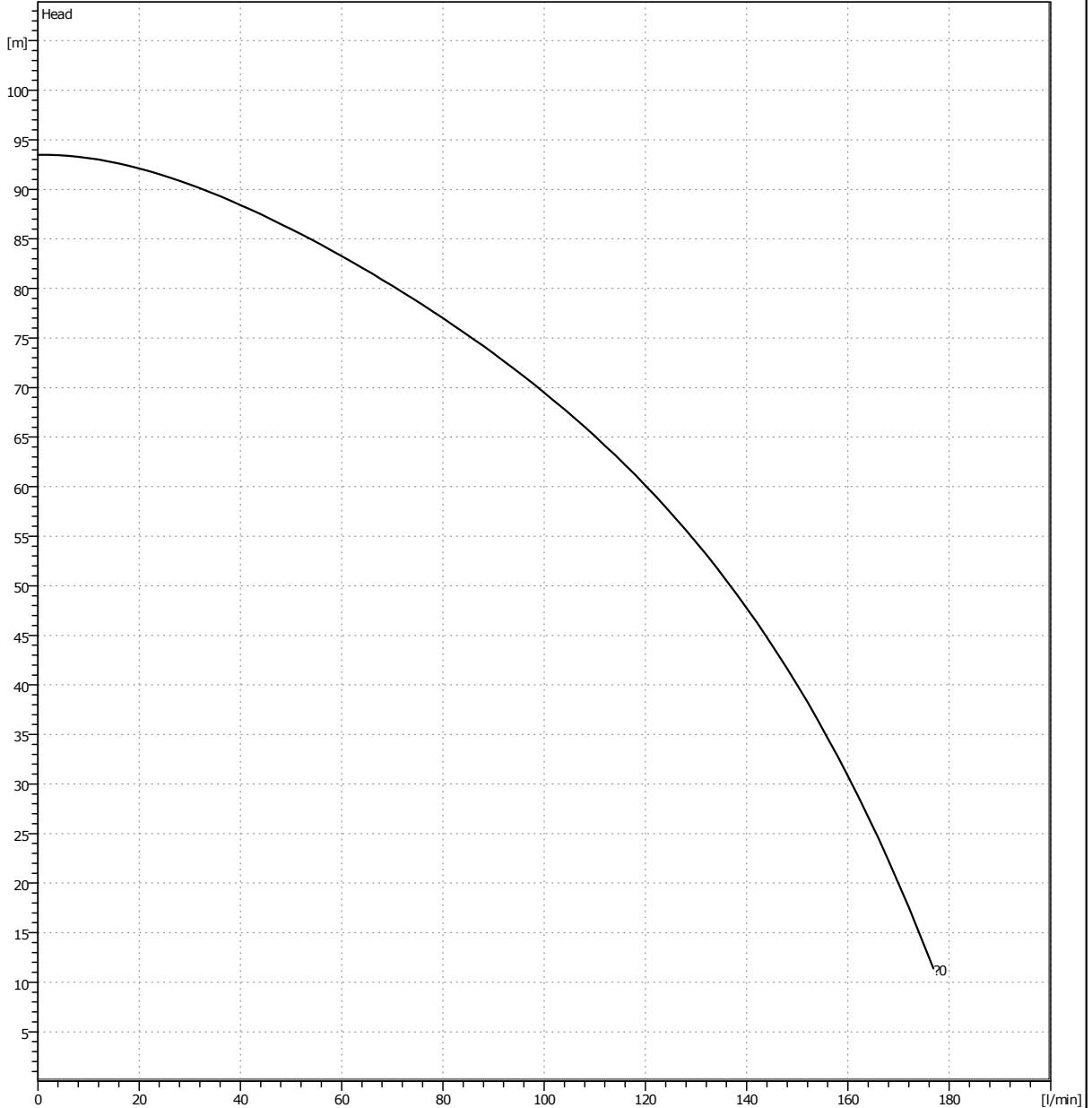

*Performance curve of some models is subject to have 10% deviation.

*Subject to change without prior notice.

| | |
|---------|------------------------|
| TYPE | Multi Stage Horizontal |
| MODEL | PBI-406UA |
| SERVICE | |

Sectional Drawing

| | |
|-----------|------------|
| Sheet No. | |
| Customer | |
| Item No. | |
| Date | 2017-03-28 |

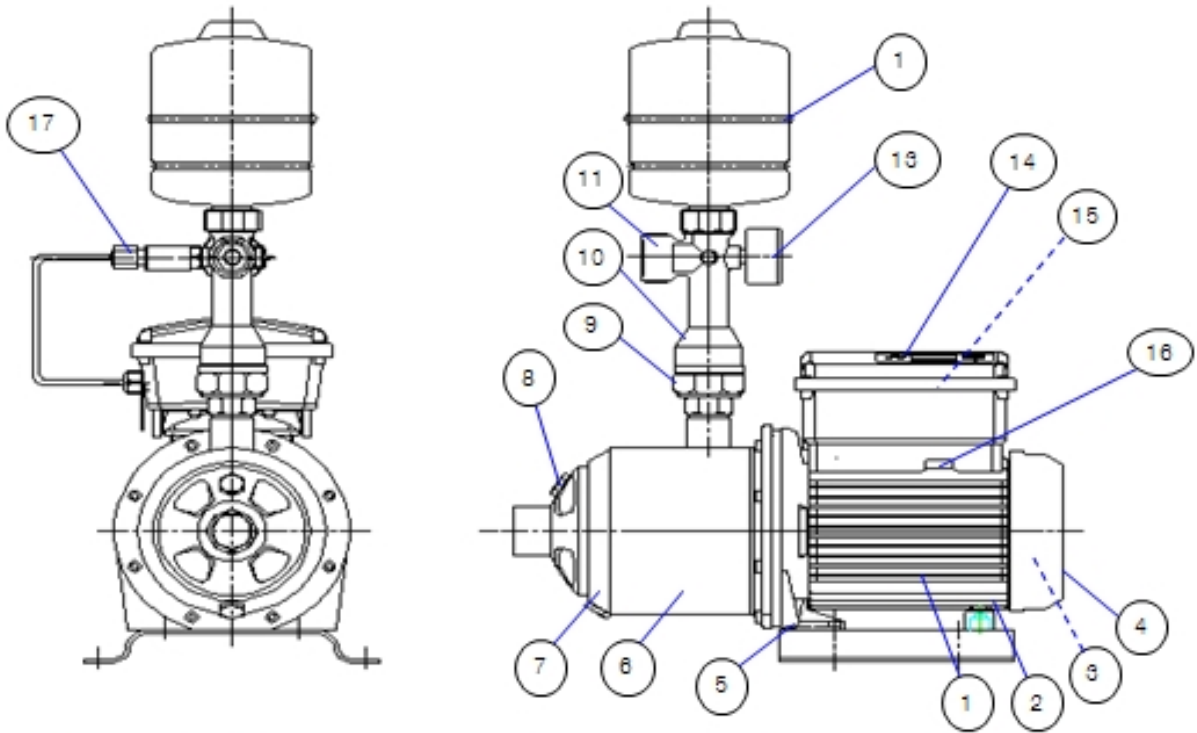

| Cls. | Part Name | Specification | Quantity | Remarks |
|------|-------------------|--------------------|----------|---------|
| 1 | Motor Assembly | 3phase 220V 60Hz | 1 | |
| 2 | Motor supporter | ABS(HI-100) | 1 | |
| 3 | Fan | PBT(GP-2200) | 1 | |
| 4 | Fan Cover | SCP or ABS(HI-100) | 1 | |
| 5 | Base Plate | SCP | 1 | |
| 6 | Casing | STS304 | 1 | |
| 7 | Drain Plug | STS316L | 1 | |
| 8 | Priming Plug | STS316L | 1 | |
| 9 | Union Assembly | Brass or STS304 | 1 | |
| 10 | Check Valve | STS304 | 1 | |
| 11 | Cross Nipple | Brass or STS304 | 1 | |
| 12 | Pressure Tank | SCP/Rubber | 1 | |
| 13 | Pressure Gauge | 16bar | 1 | |
| 14 | Inverter Cover | ABS(AF-305F) | 1 | |
| 15 | Inverter Assembly | - | 1 | |
| 16 | Inverter Base | ABS(AF-305F) | 1 | |
| 17 | Transmitter | 16bar | 1 | |

| | |
|---------|------------------------|
| TYPE | Multi Stage Horizontal |
| MODEL | PBI-406UA |
| SERVICE | |