

wilo Pump Data Sheet

Sheet No.	
Customer	
Item No.	
Date	2017-03-28

1	Model	PBI-804UA		Title	
2	Location			Agent	
3	Service			Plant Name	
4	Quantity	Set(s)	Installation	<input checked="" type="checkbox"/> Indoor	<input type="checkbox"/> Outdoor
5	OPERATING CONDITION				
6	Liquid	Water		Capacity	200 lpm (at Ht=54m)
7	Pumping Temp.	0~40		Suct. Head	0 m
8	S.G	1		Disch. Head	40 m
9	Vap. Pressure	1kg/cm2A		Total head	40 m
10	Viscosity	1 cp			
11	PERFORMANCE AND CONSTRUCTIONS			MATERIAL	
12	Horizontal		Efficiency	%	
13	No. of Stages	4	Rated Power	2.5KW	
14	Speed	3450rpm	NPSHre	Shaft	
15	Rotation	CCW (view from drive end)		Casing	
16	Bore	Size(Dia)	Rating	Face	Position
17	Suction	40 mm			End
18	Discharge	32 mm			Top
19	Impeller Type	Closed	Single suction		HYDROSTATIC
20	Flow Direction	Radial		Casing	10 kgf/cm2
21	Shaft Seal	M/Seal	Shaft Sleeve	No	Pressure Tank
22	Mounting	Foot		TESTING	
23	Lubrication	<input checked="" type="checkbox"/> Grease	<input type="checkbox"/> Oil Bath		Items
24	Cooling	<input type="checkbox"/> Stuff.Box	<input type="checkbox"/> B/R Housing	<input checked="" type="checkbox"/> No Cooling	Run Perform.
25	Pump Side	6302ZZ	Fan Side	6202ZZ	Hydrostatic
26	DRIVER SPECIFICATION			SPARE PARTS	
27	Maker	WILO	Phase / V / Hz	3 ~ 380V ~ 60Hz	
28	Type	Induction Motor	Motor Frame No.		
29	Power	2.5KW	Furnished by	<input checked="" type="checkbox"/> WILO	<input type="checkbox"/> Customer
30	Pole & Speed	2p 3450rpm	Mounted by	<input checked="" type="checkbox"/> WILO	<input type="checkbox"/> Customer
31	Insulation	F	Protection	IP X4	
32	ACCESSORIES(<input checked="" type="checkbox"/>Supplied : WILO)				
33	<input type="checkbox"/> Common Base				
34	<input type="checkbox"/> Foundation Bolts & Nuts				
35	<input type="checkbox"/> Coupling	No	<input type="checkbox"/> Coupling Guard		
36	<input type="checkbox"/> Pressure Gauge				
37	<input type="checkbox"/> Collar or Plug for Drain & Air vent.				
38	<input type="checkbox"/> Seal Flushing				
39	M/Seal	Maker	Burgmann	Model & Size	14
40		Type	MG1/14-G606	Cooler	<input type="checkbox"/> Yes <input checked="" type="checkbox"/> No
41					
42	<input type="checkbox"/> Companion Flanges			Weight	
43	<input type="checkbox"/> Special Tool				
44					
45				Total Wt.	21 kg

Estimated Performance Curve

Sheet No.	
Customer	
Item No.	
Date	2017-03-28

SPECIFICATION

PUMP	Capacity	200 lpm (att Ht=54m)	MOTOR	OUTPUT	2.5KW
	Total Head	40 m		VOLTAGE	380V
	SUCTION BORE	40 mm		FREQUENCY	60 Hz
	DISCHARGE BORE	32 mm		SPEED	3550 1/min
	LIQUID	WATER		TYPE	Induction Motor
	MAKER	WILO		MAKER	WILO

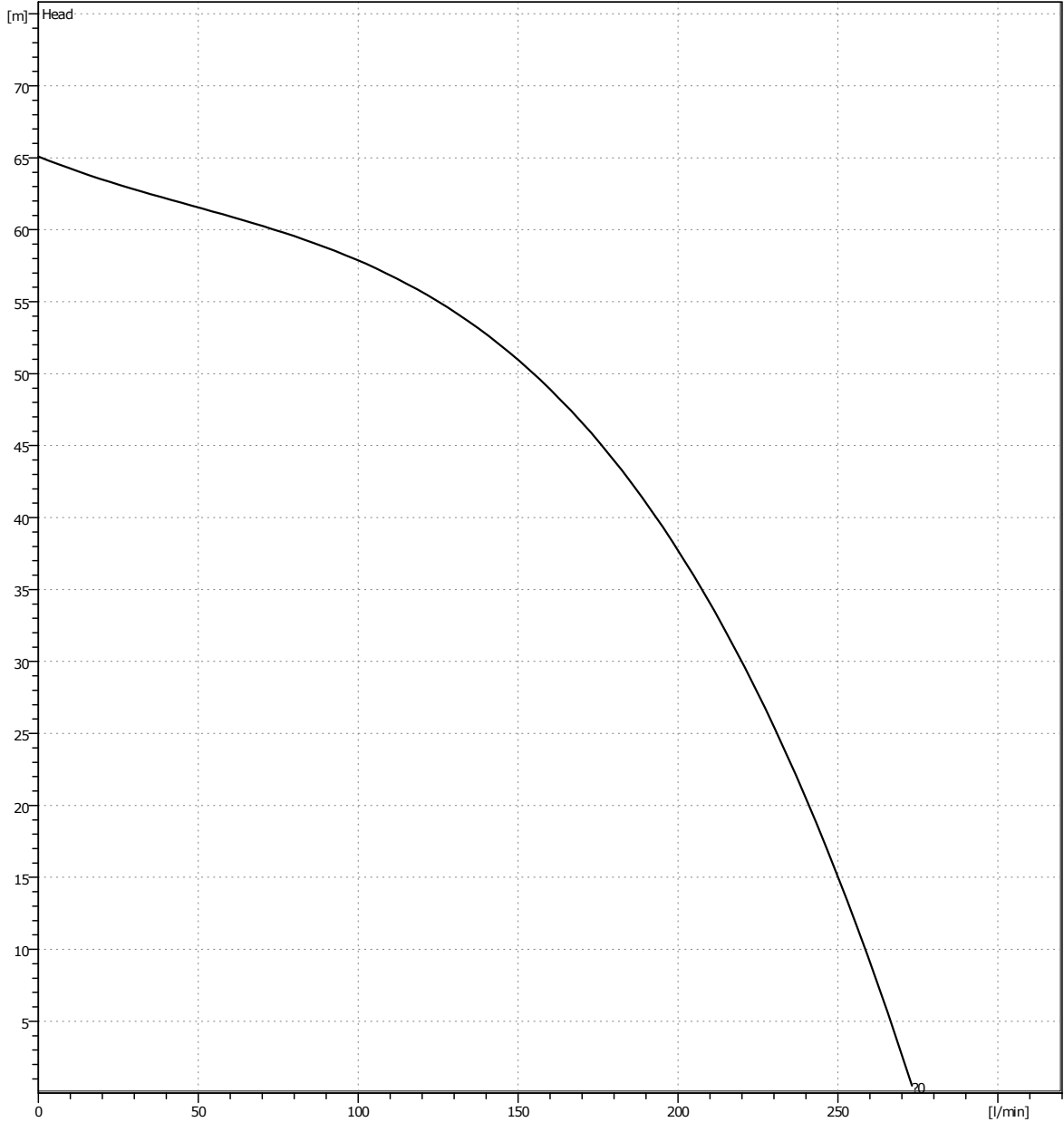

*Performance curve of some models is subject to have 10% deviation.
 *Subject to change without prior notice.

TYPE	Muiti Stage Horizontal
MODEL	PBI-804UA
SERVICE	

Outline Drawing

Sheet No.	
Customer	
Item No.	
Date	2017-03-28

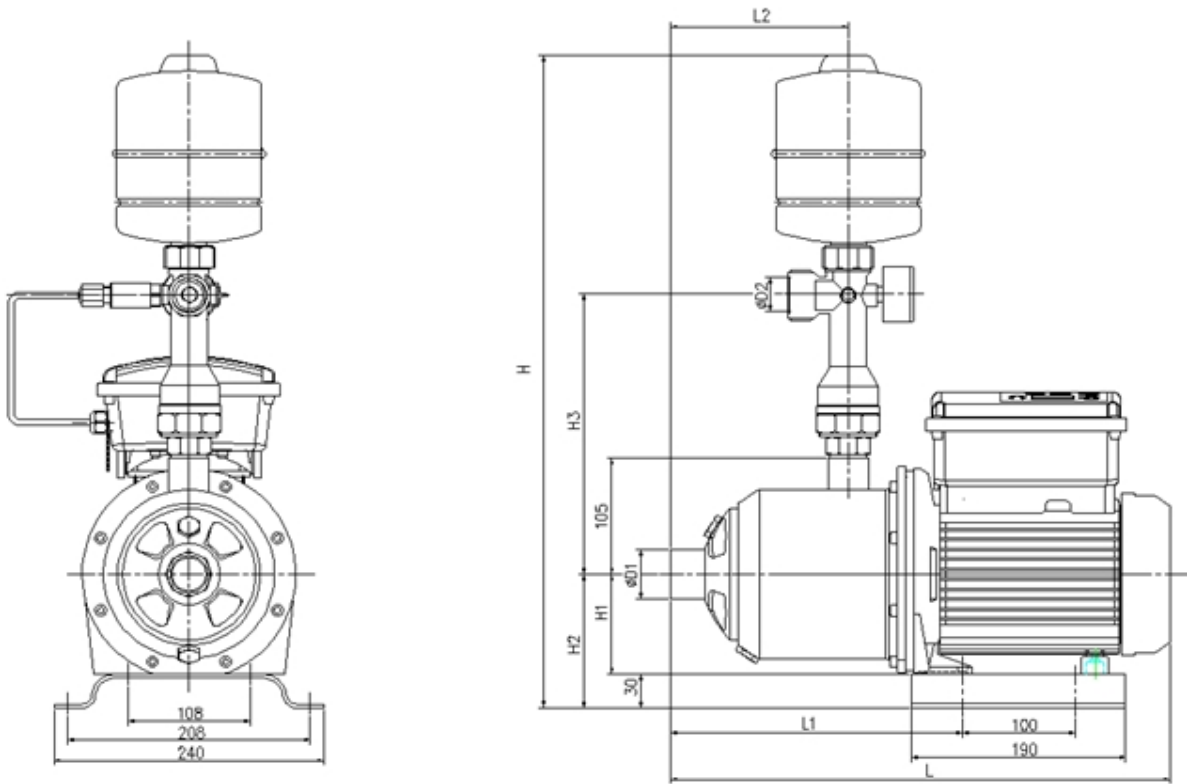

모델명	Dimension(mm)										중량 (kg)
	H	H1	H2	H3	L	L1	L2	ΦD1	ΦD2		
PBI-203MA	610	90	120	380	385	185	109.5	1"	1"	13	
PBI-205MA	610	90	120	380	430	235	157.5	1"	1"	15	
PBI-402MA	610	90	120	380	385	185	109.5	1 1/4"	1"	14	
PBI-403MA	610	90	120	380	385	185	109.5	1 1/4"	1"	17	
PBI-404MA	610	90	120	380	425	225	157.5	1 1/4"	1"	17	
PBI-405MA	610	90	120	380	425	225	157.5	1 1/4"	1"	18	
PBI-406UA	580	100	104	465	484	276	181.5	1 1/4"	1"	20	
PBI-802MA	630	90	120	385	390	190	121.5	1 1/2"	1 1/4"	18	
PBI-803MA	630	90	120	385	390	190	121.5	1 1/2"	1 1/4"	19	
PBI-804UA	610	100	104	465	484	276	181.5	1 1/2"	1 1/4"	21	

--	--	--	--	--	--	--	--	--	--	--	--	--	--	--	--	--	--	--	--

TYPE	Multi Stage Horizontal
MODEL	PBI-804UA
SERVICE	

Sectional Drawing

Sheet No.	
Customer	
Item No.	
Date	2017-03-28

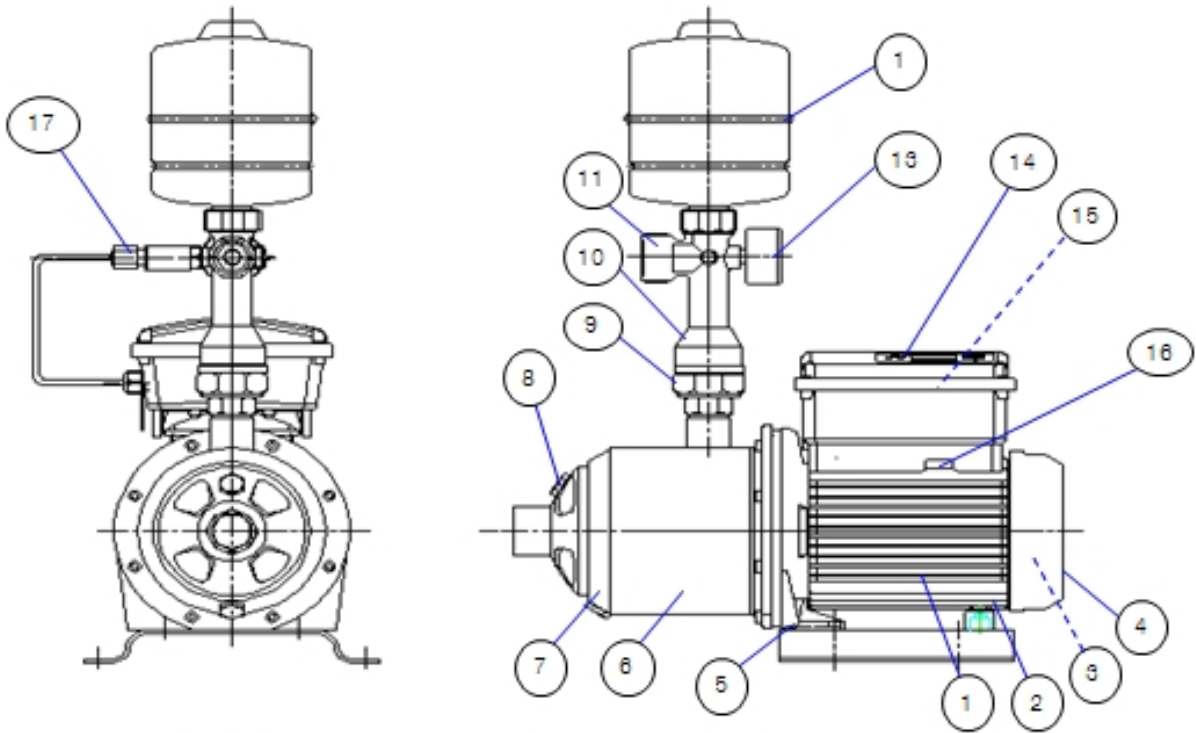

Cls.	Part Name	Specification	Quantity	Remarks
1	Motor Assembly	3phase 220V 60Hz	1	
2	Motor supporter	ABS(HI-100)	1	
3	Fan	PBT(GP-2200)	1	
4	Fan Cover	SCP or ABS(HI-100)	1	
5	Base Plate	SCP	1	
6	Casing	STS304	1	
7	Drain Plug	STS316L	1	
8	Priming Plug	STS316L	1	
9	Union Assembly	Brass or STS304	1	
10	Check Valve	STS304	1	
11	Cross Nipple	Brass or STS304	1	
12	Pressure Tank	SCP/Rubber	1	
13	Pressure Gauge	16bar	1	
14	Inverter Cover	ABS(AF-305F)	1	
15	Inverter Assembly	-	1	
16	Inverter Base	ABS(AF-305F)	1	
17	Transmitter	16bar	1	

TYPE	Muiti Stage Horizontal
MODEL	PBI-804UA
SERVICE	