

# wilo Pump Data Sheet

Sheet No.	
Customer	
Item No.	
Date	2017-03-23

1	<b>MODEL</b>	PSV-1210E_IE2		Title		
2	Location			Agent		
3	Service			Plant Name		
4	Quantity	Set(s)		Installation	<input checked="" type="checkbox"/> Indoor <input type="checkbox"/> Outdoor	
5	<b>OPERATING CONDITION</b>					
6	Liquid	Water		Flow	2500 l/min	
7	Pumping Temp.	Ambient		Suc. Pressure		
8	S.G.	1		Dis. Pressure		
9	Vap. Pressure	0.03kg/cm2A at 24?		Diff. Pressure		
10	Viscosity	1 cP		Total Head	46 m	
11	<b>PERFORMANCE AND CONSTRUCTION</b>				<b>MATERIAL</b>	
12	Horizontal		Efficiency	65 %	Part Name	Symbol
13	No. of Stages	1	Rated Power	29 kW	Casing&Cover	GC200
14	Speed	1750 rpm	NPSHre		Casing Ring	GC200
15	Rotation	CW (view from drive end)			Impeller	GC200
16	<b>BORE</b>	Size(Dia)	Rating	Face	Position	Shaft
17	Suction	125 mm	10kgf/cm2	RF	End	Sleeve
18	Discharge	100 mm	10kgf/cm2	RF	Top	B/R Housing
19	Impeller Type	Closed	Single Stage Volute		<b>HYDROSTATIC</b>	
20	Flow Direction	Radial		Casing		3 min
21	Shaft Seal	M/Seal	Shaft Sleeve	Yes	Jacket	3 min
22	Mounting	Foot		<b>TESTING</b>		
23	Lubrication	<input checked="" type="checkbox"/> Grease <input type="checkbox"/> Oil Bath		Items		Witness
24	Cooling	<input type="checkbox"/> Stuff.Box <input type="checkbox"/> B/R Housing <input checked="" type="checkbox"/> No Cooling		Run Perform.	<input checked="" type="checkbox"/> Yes <input type="checkbox"/> No	<input type="checkbox"/> Yes <input checked="" type="checkbox"/> No
25	Radial Bearing	6307zzC3	Thrust Bearing	6308zzC3	Hydrostatic(Air Press.)	<input checked="" type="checkbox"/> Yes <input type="checkbox"/> No <input type="checkbox"/> Yes <input checked="" type="checkbox"/> No
26	<b>MOTOR SPECIFICATION</b>				<b>SPARE PART</b>	
27	Maker	HIGEN	Phase / V / Hz	3~ <input checked="" type="checkbox"/> 380V <input type="checkbox"/> ~60 Hz		Set(s)
28	Type	TEFC	Motor Frame No.	180 L		Set(s)
29	Power	30 kW	Furnished by	<input checked="" type="checkbox"/> WILO <input type="checkbox"/> Customer		Set(s)
30	No. of Pole	4 P	Mounted by	<input checked="" type="checkbox"/> WILO <input type="checkbox"/> Customer		Set(s)
31	Insulation	<input checked="" type="checkbox"/> F <input type="checkbox"/>	Enclosure	<input checked="" type="checkbox"/> IP 54 <input type="checkbox"/>		Set(s)
32	<b>ACCESSORY(<input checked="" type="checkbox"/>Supplied : WILO)</b>					Set(s)
33	<input checked="" type="checkbox"/> Common Base	Steel Channel				Set(s)
34	<input type="checkbox"/> Foundation Bolts & Nuts					Set(s)
35	<input checked="" type="checkbox"/> Coupling	<input checked="" type="checkbox"/> Flange <input type="checkbox"/>	<input checked="" type="checkbox"/> Coupling Guard			Set(s)
36	<input type="checkbox"/> Pressure Guage					Set(s)
37	<input type="checkbox"/> Plug for Drain & Air vent.					Set(s)
38	<input type="checkbox"/> Seal Flushing					Set(s)
39	M/Seal	Maker	KSM	Model & Size	S1A /45	Set(s)
40		Type	Unbalanced	Cooler	<input type="checkbox"/> Yes <input checked="" type="checkbox"/> No	Set(s)
41		API 610 Plan				
42		Material Code	Ceramic/Carbon,Viton		Pump	81 kg
43	<input type="checkbox"/> Companion Flanges				Bed	66 kg
44	<input type="checkbox"/> Special Tool				Motor	210 kg
					Total wt.	357 kg

\*Pump test acceptance grade in accordance with ISO 9906:2012, Grade 2B.

# Estimated Performance Curve

Sheet No.	
Customer	
Item No.	
Date	2017-03-23

## SPECIFICATION

PUMP		MOTOR	
CAPACITY	2500 l/min	OUTPUT	30 kW
TOTAL HEAD	46 m	VOLTAGE	<input checked="" type="checkbox"/> 380V <input type="checkbox"/>
SUCTION BORE	125 mm	FREQUENCY	60 Hz
DISCHARGE BORE	100 mm	SPEED	1750 1/min
LIQUID	WATER	TYPE	TEFC
MAKER	WILO	MAKER	HIGEN

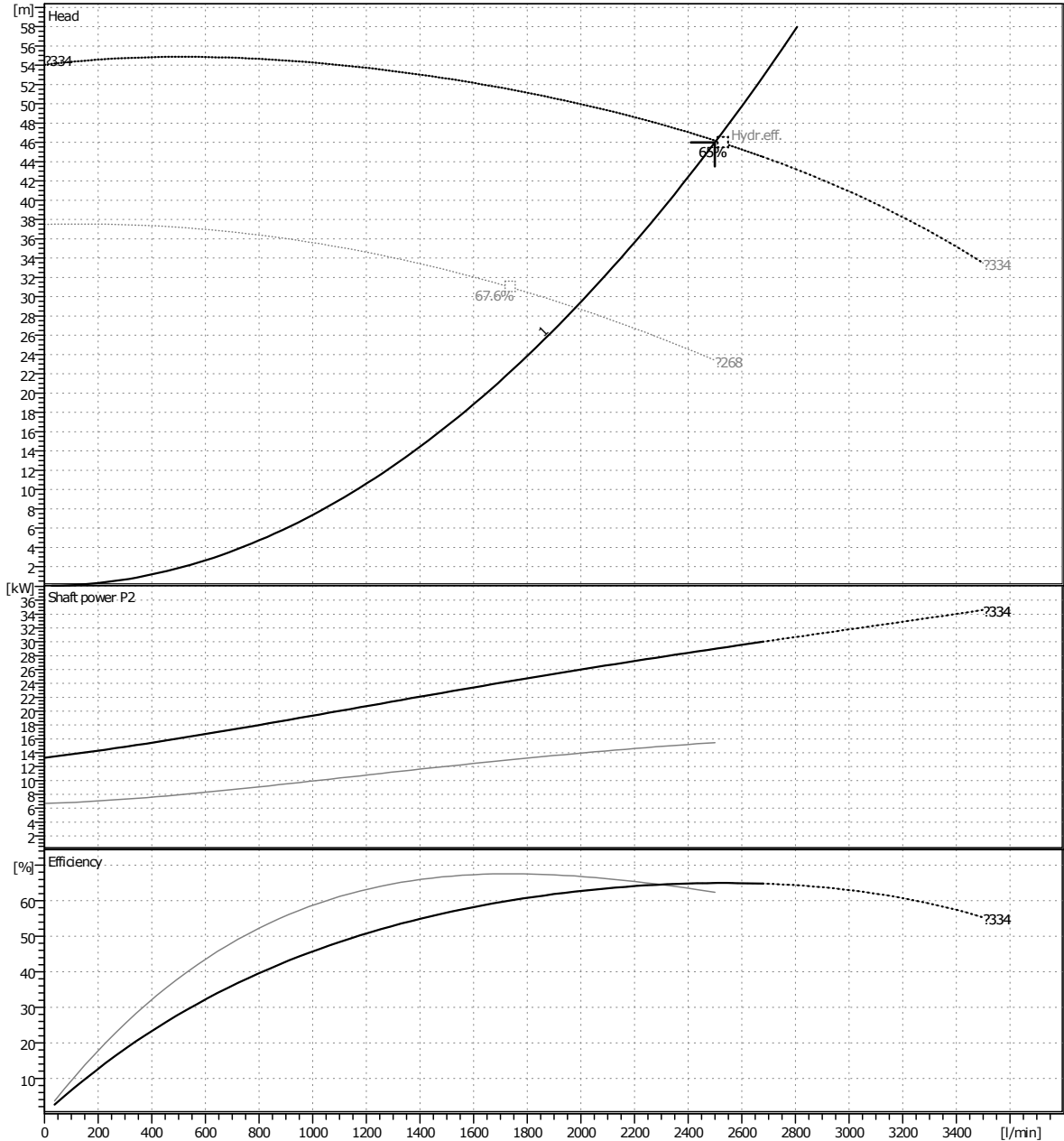

\* Pump test acceptance grade in accordance with ISO 9906:2012, Grade 2B.

\* Subject to change without prior notice.

TYPE	Single Stage Volute
MODEL	PSV-1210E IE2
SERVICE	

# Outline Drawing

Sheet No.	
Customer	
Item No.	
Date	2017-03-23

## SPECIFICATION

<b>PUMP</b>	CAPACITY	2500 l/min	<b>MOTOR</b>	OUTPUT	30 kW
	TOTAL HEAD	46 m		VOLTAGE	<input checked="" type="checkbox"/> 380V <input type="checkbox"/>
	SUCTION BORE	125 mm		FREQUENCY	60 Hz
	DISCHARGE BORE	100 mm		SPEED	1750 1/min
	LIQUID	WATER		TYPE	TEFC
	MAKER	WILO		MAKER	HIGEN

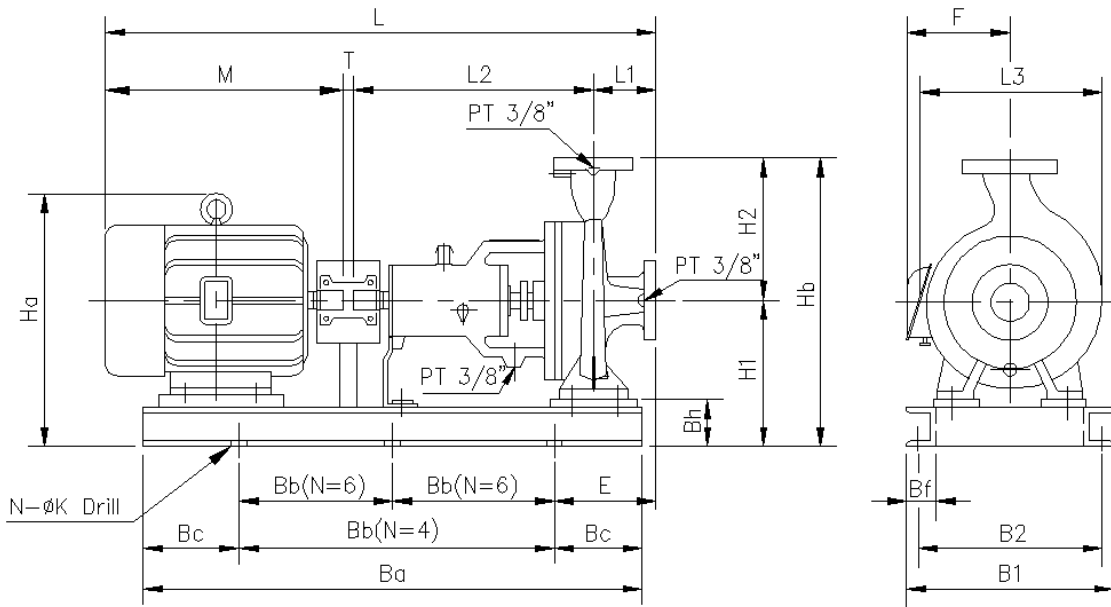

\* Dimension of outline drawing subjects to change without prior notice.

L1	140	Hb	675	E	200
L2	470	Ha	606	B1	440
L3	460	Bh	110	B2	395
L	1304	T	4	N	6
M	690	Ba	1150	K	19
H1	360	Bb	425	F	286
H2	315	Bc	150	Bf	50

TYPE	Single Stage Volute
MODEL	PSV-1210E_IE2
SERVICE	

# Sectional Drawing

Sheet No.	
Customer	
Item No.	
Date	2017-03-23

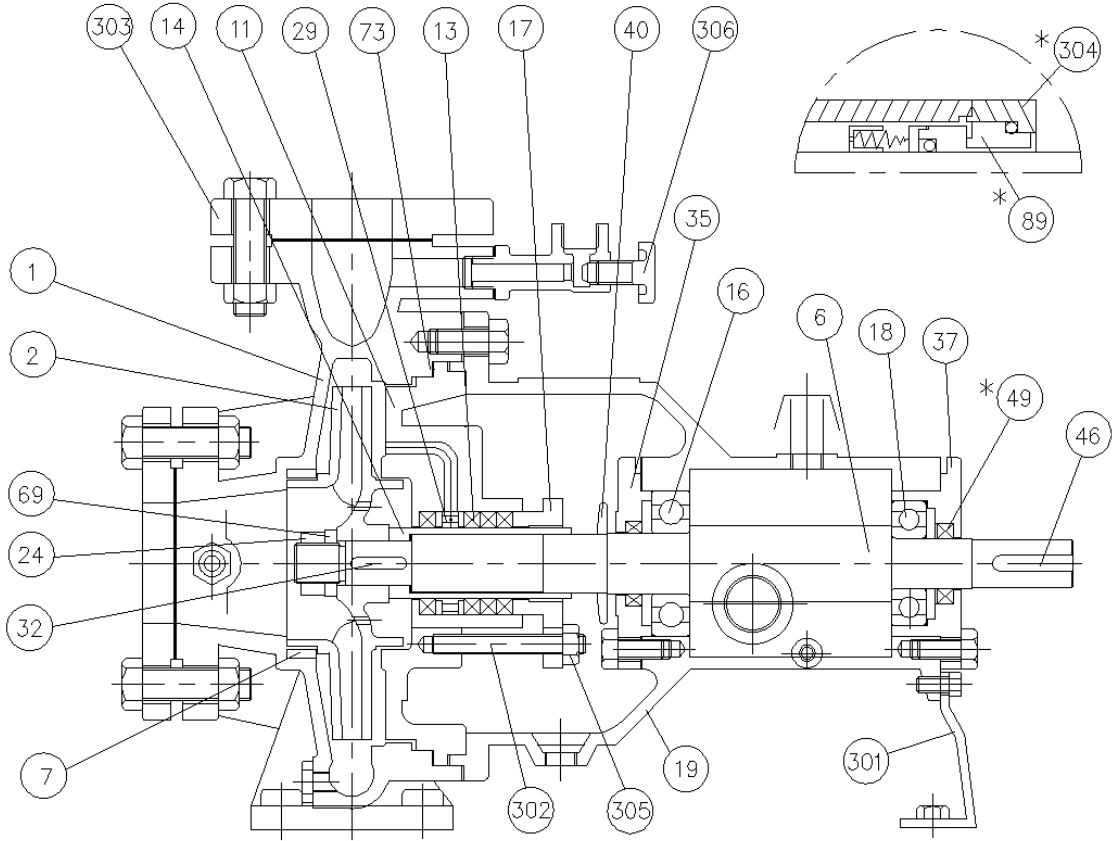

<REFERENCE>

\* MARK : OPTION PARTS

# MARK : SPARE PARTS

No.	Part Name	Material	Qt'y	No.	Part Name	Material	Qt'y
1	Casing	GC200	1	35	Bearing Cover(A)	GC200	1
#2	Impeller	GC200	1	37	Bearing Cover(B)	GC200	1
6	Shaft	SCM440	1	40	Deflector	NR610	1
7	Casing Ring	GC200	1	46	Coupling Key	SM45C	1
11	Casing Cover	GC200	1	*49	Oil Seal	NBR	2
13	Gland Packing	Fabric	4	69	Impeller Washer	STS304	1
#14	Sleeve	STS304	1	#73	Casing Gasket	NBR	1
#16	Ball Bearing(A)	STB2	1	*89	Mechanical Seal	-	1
17	Gland	GC200	1	301	Support	SCP1	1
#18	Ball Bearing(B)	STB2	1	302	Gland Bolt	STS304	2/4
19	Bearing Housing	GC200	1	*303	Companion Flange	-	
24	Impeller Nut	STS304	1	*304	M/Seal Cover	SM45C	1
29	Lantern Ring	NORYL/HBsC1	1	305	Nut	C3602BD	2/4
#32	Impeller Key	SCM440	1	306	Priming Pipe	HBsC1	1

TYPE	Single Stage Volute
MODEL	PSV-1210E_IE2
SERVICE	