

Estimated Performance Curve

Sheet No.	
Customer	
Item No.	
Date	2017-03-07

SPECIFICATION

PUMP	Capacity	120 lpm at 21 m	MOTOR	OUTPUT	1100W
	Total Head	30 m		VOLTAGE	220V
	SUCTION BORE	32 mm		FREQUENCY	60Hz
	DISCHARGE BORE	25 mm		SPEED	3450rpm
	LIQUID	WATER		TYPE	TEFC
	MAKER	WILO		MAKER	WILO

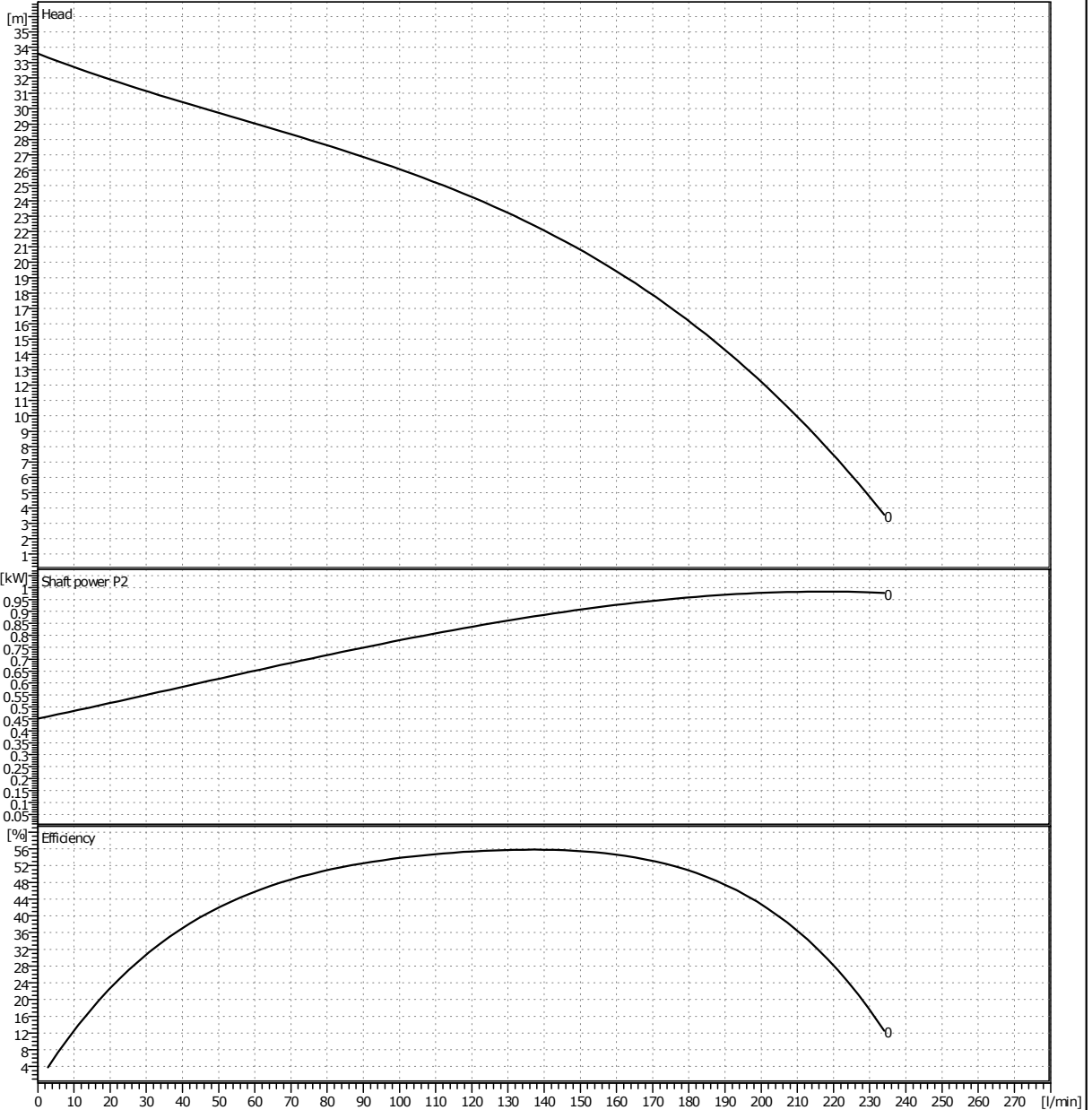

* Performance curve of some models is subject to have 10% deviation.

* Subject to change without prior notice.

TYPE	Horizontal Multi-stage
MODEL	HSS-1100M
SERVICE	

Outline Drawing

Sheet No.	
Customer	
Item No.	
Date	2017-03-07

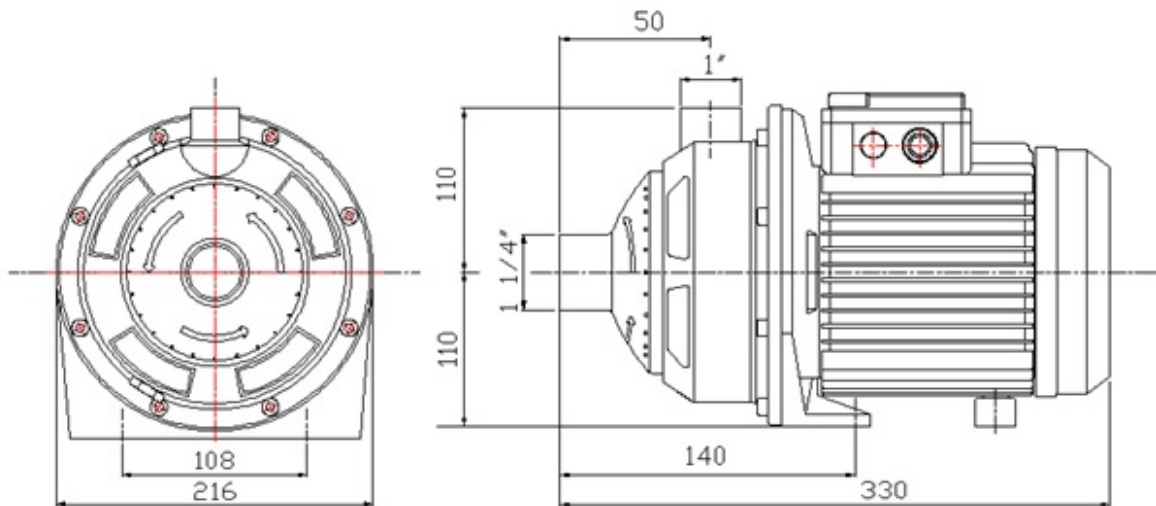

TYPE	Horizontal Multi-stage
MODEL	HSS-1100M
SERVICE	