

wilo Pump Data Sheet

| | |
|-----------|------------|
| Sheet No. | |
| Customer | |
| Item No. | |
| Date | 2017-02-09 |

| | | | | | | | |
|----|--|--|----------------------|--|---|---|---|
| 1 | MODEL | Helix V1613 / PN25 | | Title | | | |
| 2 | Location | | | Agent | | | |
| 3 | Service | | | Plant Name | | | |
| 4 | Quantity | Set(s) | | Installation | <input checked="" type="checkbox"/> Indoor <input type="checkbox"/> Outdoor | | |
| 5 | OPERATING CONDITION | | | | | | |
| 6 | Liquid | Water | | Flow | 0 l/min | | |
| 7 | Pumping Temp. | Ambient | | Suc. Pressure | | | |
| 8 | S.G. | 1 | | Dis. Pressure | | | |
| 9 | Vap. Pressure | 0.03kg/cm2A at 24? | | Diff. Pressure | | | |
| 10 | Viscosity | 1 cP | | Total Head | 0 m | | |
| 11 | PERFORMANCE AND CONSTRUCTION | | | | | MATERIAL | |
| 12 | Vertical | Efficiency | | | % | Part Name | Symbol |
| 13 | No. of Stages | 13 | Rated Power | | | Casing | GC250 |
| 14 | Speed | 3550 rpm | NPSHre | | | Impeller | STS304L |
| 15 | Rotation | CW (view from drive end) | | | | Shaft | STS304 |
| 16 | Bore | Size(Dia) | Rating | Face | Position | Tube | STS304 |
| 17 | Suction | 50 mm | PN 25 | RF | Side | Diffuser | STS304L |
| 18 | Discharge | 50 mm | PN 25 | RF | Side | Top Cover | STS304 |
| 19 | Impeller Type | Closed | Vertical Multi-Stage | | HYDROSTATIC | | |
| 20 | Flow Direction | Radial | | Casing | | | 3 min |
| 21 | Shaft Seal | M/Seal | Shaft Sleeve | No | Jacket | 3 min | |
| 22 | Mounting | Foot | | TESTING | | | |
| 23 | Lubrication | <input checked="" type="checkbox"/> Grease | | Items | | | Witness |
| 24 | Cooling | <input checked="" type="checkbox"/> No Cooling | | Run Perform. | <input checked="" type="checkbox"/> Yes <input type="checkbox"/> No | <input type="checkbox"/> Yes <input checked="" type="checkbox"/> No | |
| 25 | Radial Bearing | - | Thrust Bearing | - | Hydrostatic(Air Press.) | <input checked="" type="checkbox"/> Yes <input type="checkbox"/> No | <input type="checkbox"/> Yes <input checked="" type="checkbox"/> No |
| 26 | MOTOR SPECIFICATION | | | | | SPARE PART | |
| 27 | Supplier | WILO | Phase / V / Hz | 3~ | 380V | ~ 60 Hz | Set(s) |
| 28 | Type | TEFC | Furnished by | <input checked="" type="checkbox"/> WILO | <input type="checkbox"/> Customer | | Set(s) |
| 29 | Power | 18.5 kW | Mounted by | <input checked="" type="checkbox"/> WILO | <input type="checkbox"/> Customer | | Set(s) |
| 30 | No. of Pole | 2 P | Enclosure | <input checked="" type="checkbox"/> IP 55 | <input type="checkbox"/> | | Set(s) |
| 31 | Insulation | <input checked="" type="checkbox"/> F <input type="checkbox"/> | | | | | Set(s) |
| 32 | ACCESSORY(<input checked="" type="checkbox"/>Supplied : WILO) | | | | | Set(s) | |
| 33 | <input type="checkbox"/> Common Base | | | | | Set(s) | |
| 34 | <input type="checkbox"/> Foundation Bolts & Nuts | | | | | Set(s) | |
| 35 | <input checked="" type="checkbox"/> Coupling | Half (Rigid & Split Type) | | <input checked="" type="checkbox"/> Coupling Guard | | Set(s) | |
| 36 | <input type="checkbox"/> Pressure Guage | | | | | Set(s) | |
| 37 | <input checked="" type="checkbox"/> Plug for Drain & Air vent. | | | | | Set(s) | |
| 38 | <input type="checkbox"/> Seal Flushing | | | | | Set(s) | |
| 39 | M/Seal | Maker | Eagle-Burgmann | Model & Size | RMG12 | | Set(s) |
| 40 | | Type | Unbalance | Cooler | <input type="checkbox"/> Yes <input checked="" type="checkbox"/> No | | Set(s) |
| 41 | | API 610 Plan | | | | | |
| 42 | | Material Code | TC/Carbon,EPDM | | | Pump | 220 kg |
| 43 | <input type="checkbox"/> Companion Flanges | | | | | | |
| 44 | <input type="checkbox"/> Special Tool | | | | | | |
| | | | | | | Total wt. | 220 kg |

*Pump test acceptance grade in accordance with ISO 9906:2012, Grade 2B.

Estimated Performance Curve

| | |
|-----------|------------|
| Sheet No. | |
| Customer | |
| Item No. | |
| Date | 2017-02-09 |

SPECIFICATION

| PUMP | | MOTOR | |
|----------------|---------|-----------|------------|
| CAPACITY | 0 l/min | OUTPUT | 18.5 kW |
| TOTAL HEAD | 0 m | VOLTAGE | 380V |
| SUCTION BORE | 50 mm | FREQUENCY | 60 Hz |
| DISCHARGE BORE | 50 mm | SPEED | 3550 1/min |
| LIQUID | WATER | TYPE | TEFC |
| MAKER | WILO | SUPPLIER | WILO |

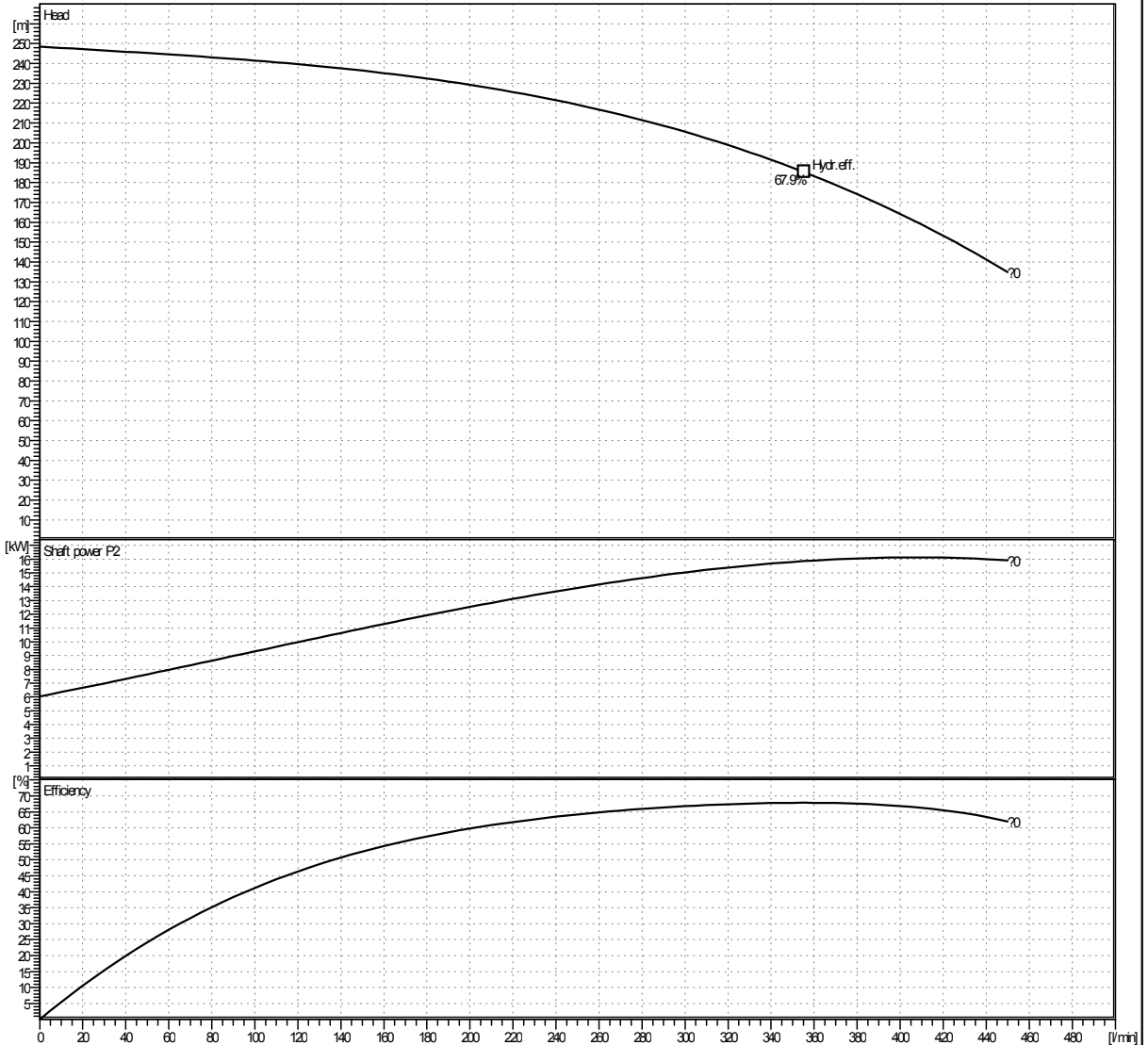

| A/B Efficiency | Capacity | Efficiency(%) |
|----------------|-------------|---------------|
| A Efficiency | 355.5 l/min | 67.9 |
| B Efficiency | | |

* Pump test acceptance grade in accordance with ISO 9906:2012, Grade 2B.

* Subject to change without prior notice.

| | |
|---------|----------------------|
| TYPE | Vertical Multi-Stage |
| MODEL | Helix V1613 / PN25 |
| SERVICE | |

Outline Drawing

| | |
|-----------|------------|
| Sheet No. | |
| Customer | |
| Item No. | |
| Date | 2017-02-09 |

SPECIFICATION

| | | | | | |
|-------------|----------------|---------|--------------|-----------|------------|
| PUMP | CAPACITY | 0 l/min | MOTOR | OUTPUT | 18.5 kW |
| | TOTAL HEAD | 0 m | | VOLTAGE | 380V |
| | SUCTION BORE | 50 mm | | FREQUENCY | 60 Hz |
| | DISCHARGE BORE | 50 mm | | SPEED | 3550 1/min |
| | LIQUID | WATER | | TYPE | TEFC |
| | MAKER | WILO | | SUPPLIER | WILO |

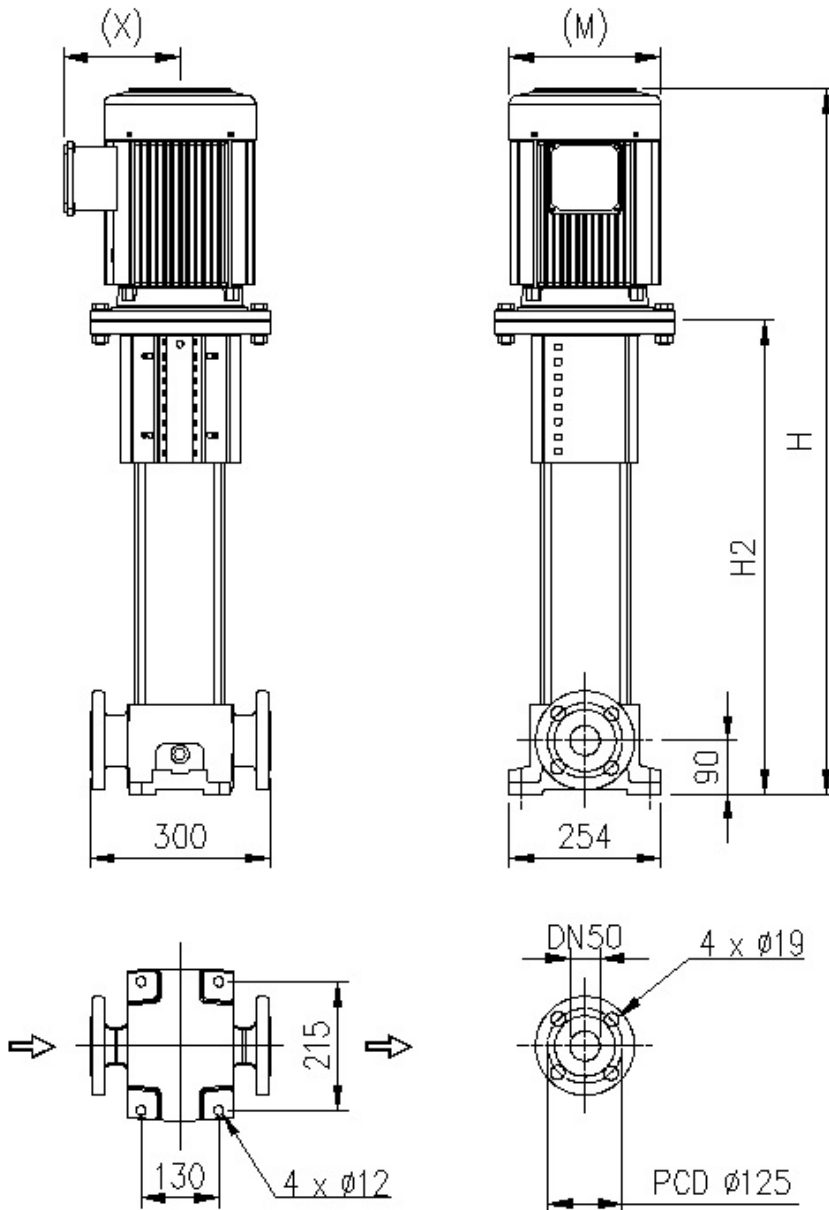

* Dimension of outline drawing subjects to change without prior notice.

| | | | | | | | |
|---|------|----|------|---|-----|---|-----|
| H | 1807 | H2 | 1271 | M | 318 | X | 285 |
|---|------|----|------|---|-----|---|-----|

| | |
|---------|----------------------|
| TYPE | Vertical Multi-Stage |
| MODEL | Helix V1613 / PN25 |
| SERVICE | |

Sectional Drawing

| | |
|-----------|------------|
| Sheet No. | |
| Customer | |
| Item No. | |
| Date | 2017-02-09 |

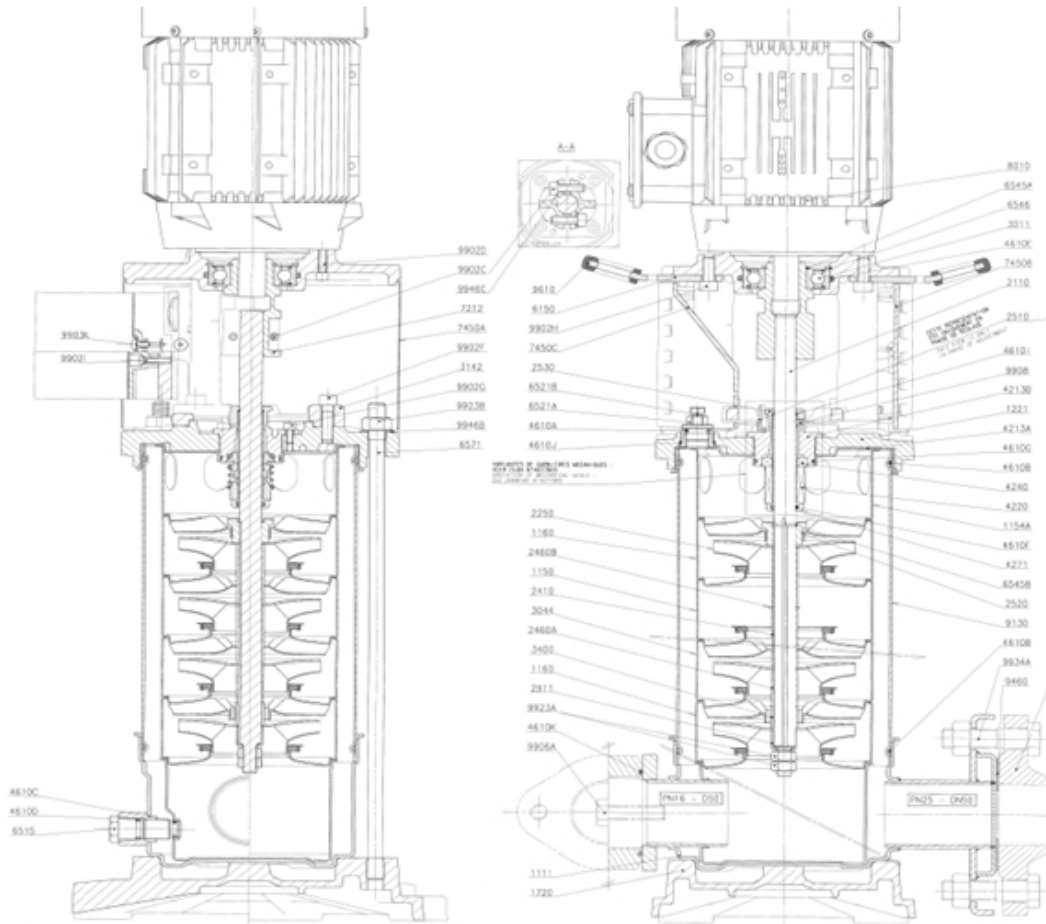

| No. | Description | No. | Description | No. | Description |
|-------|---|-------|--------------------------------------|-------|---------------------------------|
| 1111 | Pump casing | 2472 | Hub | 6571 | Tie bolt |
| 1150 | Stage casing with return guide vane serial 16 | 6548 | Stop-rush | 8010 | Motor |
| 1160 | Stage casing without return guide vane serial 16 | 7021 | Spacer | 9130 | Tube |
| 1160 | Stage casing without return guide vane serial 16 | 7212 | Coupling | 9908 | Screw |
| 1154A | Discharge chamber with return guide vane serial 16 | 9902A | Shaft end upper screw | 1221 | End shield |
| 4213A | Assembled ring cover of mechanical seal | 9902J | Screw for spacer | 2460A | Sleeve spacer |
| 2110 | Pump shaft | 9906E | Screw fix. motor | 2460B | Flat washer |
| 2250 | Impeller m+16 | 9946A | Washer under 9902A screw | 3400 | Shaft sleeve |
| 2410 | Spacer | 9923C | Nut for fixing motor | 1720 | Base |
| 2510 | Setting shim shaft | 4610C | O'ring drain and priming plug | 4213B | Mechanical seal ring holder |
| 2520 | Back-up ring(or Thrust ring) | 4610D | O'ring drain and priming plug | 4220 | Rotating part-mechanical seal |
| 2530 | Drive ring for mechanical seal | 4610E | O'ring ø63.10xø3.53 for ball bearing | 4240 | Stationary part-mechanical seal |
| 2911 | Shaft end washer | 4610F | O'ring | 9902C | Screw for coupling |
| 3011 | Lantern ball bearing | 4610G | O'ring | 9902D | Screw fix. motor |
| 3044 | Bearing stage casing with return guide vane serial 16 | 4610I | O'ring | 9902F | Screw fix. lantern/end shield |
| 3142 | Lantern | 4610J | O'ring | 9902G | Screw |
| 4271 | Shaft sleeve | 4610K | O'ring | 9902H | Srew fix. Platinize handling |
| 6150 | Platinize handling | 6545A | Circlip shaft for ball bearing | 9902I | Plastic support screw |
| 6515 | Drain and priming plug | 6545B | Half keeper(thrust ring) | 9906A | Screw |
| 6521 | Filing and venting plug | 7450A | Sheet coupling protector | 9923A | Shaft end nut |
| 6546 | Circlip(lantern ball bearing) | 7450 | Coupling guard support | 9923B | Nut for tie bolt |
| 9934A | Bolt | 9946B | Washer under 9923B nut | 4610B | O'ring |

| | |
|---------|----------------------|
| TYPE | Vertical Multi-Stage |
| MODEL | Helix V1613 / PN25 |
| SERVICE | |

Sectional Drawing

| | |
|-----------|------------|
| Sheet No. | |
| Customer | |
| Item No. | |
| Date | 2017-02-09 |

Up to 7.5kW

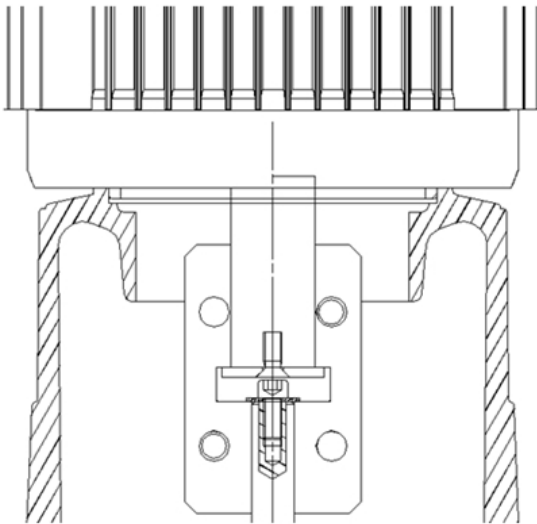

Over 11kW

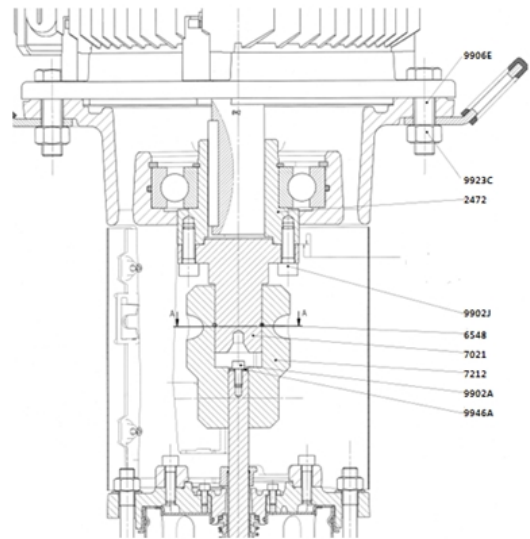

| No. | Description |
|-------|---------------------|
| 9906E | Screw fix. Motor |
| 9923C | Motor fastening nut |
| 2472 | Hub |
| 9902J | Screw for spacer |
| 6548 | Stop-rush |
| 7021 | Spacer |
| 7212 | Coupling |

| | |
|---------|----------------------|
| TYPE | Vertical Multi-Stage |
| MODEL | Helix V1613 / PN25 |
| SERVICE | |