

wilo Pump Data Sheet

Sheet No.	
Customer	
Item No.	
Date	2017-03-28

1	Model	PBI-L603MA		Title	
2	Location			Agent	
3	Service			Plant Name	
4	Quantity	Set(s)	Installation	<input checked="" type="checkbox"/> Indoor	<input type="checkbox"/> Outdoor
5	OPERATING CONDITION				
6	Liquid	Water		Capacity	70 lpm
7	Pumping Temp.	0~40		Suct. Head	0.5 m
8	S.G	1		Disch. Head	35 m
9	Vap. Pressure	1kg/cm2A		Total head	35.5 m
10	Viscosity	1 cp			
11	PERFORMANCE AND CONSTRUCTIONS			MATERIAL	
12	Horizontal	Efficiency	%		Parts' Name
13	No. of Stages	3	Rated Power	1.1kW	
14	Speed	3450rpm	NPSHre	Shaft	STS304
15	Rotation	CCW (view from drive end)		Casing	STS304
16	Bore	Size(Dia)	Rating	Face	Position
17	Suction	32 mm			Side
18	Discharge	25 mm			Top
19	Impeller Type	Closed	Single suction		HYDROSTATIC
20	Flow Direction	Radial		Casing	10 kgf/cm2 3 min
21	Shaft Seal	M/Seal	Shaft Sleeve	No	Pressure Tank 20 kgf/cm2 3 min
22	Mounting	Foot		TESTING	
23	Lubrication	<input checked="" type="checkbox"/> Grease	<input type="checkbox"/> Oil Bath		Items (Witness)
24	Cooling	<input type="checkbox"/> Stuff.Box	<input type="checkbox"/> B/R Housing	<input checked="" type="checkbox"/> No Cooling	Run Perform. <input checked="" type="checkbox"/> Yes <input type="checkbox"/> No <input type="checkbox"/> Yes <input checked="" type="checkbox"/> No
25	Pump Side	6304ZZ	Fan Side	6202ZZ	Hydrostatic <input checked="" type="checkbox"/> Yes <input type="checkbox"/> No <input type="checkbox"/> Yes <input checked="" type="checkbox"/> No
26	DRIVER SPECIFICATION			SPARE PARTS	
27	Maker	WILO	Phase / V / Hz	1 ~ 220V ~ 60Hz	
28	Type	Induction Motor	Motor Frame No.		
29	Power	1.1kW	Furnished by	<input checked="" type="checkbox"/> WILO <input type="checkbox"/> Customer	Set(s)
30	Pole & Speed	2p 3450rpm	Mounted by	<input checked="" type="checkbox"/> WILO <input type="checkbox"/> Customer	Set(s)
31	Insulation	F	Protection	IP X4	
32	ACCESSORIES(<input checked="" type="checkbox"/>Supplied : WILO)			Set(s)	
33	<input type="checkbox"/> Common Base			Set(s)	
34	<input type="checkbox"/> Foundation Bolts & Nuts			Set(s)	
35	<input type="checkbox"/> Coupling	No	<input type="checkbox"/> Coupling Guard		Set(s)
36	<input type="checkbox"/> Pressure Gauge			Set(s)	
37	<input type="checkbox"/> Collar or Plug for Drain & Air vent.			Set(s)	
38	<input type="checkbox"/> Seal Flushing			Set(s)	
39	M/Seal	Maker	Burgmann	Model & Size	14
40		Type	MG1/14-G606	Cooler	<input type="checkbox"/> Yes <input checked="" type="checkbox"/> No
41				Set(s)	
42	<input type="checkbox"/> Companion Flanges			Weight	
43	<input type="checkbox"/> Special Tool				
44					
45				Total Wt.	11 kg

Estimated Performance Curve

Sheet No.	
Customer	
Item No.	
Date	2017-03-28

SPECIFICATION

PUMP	Capacity	70 lpm at m	MOTOR	OUTPUT	1.1kW
	Total Head	35.5 m		VOLTAGE	220V
	SUCTION BORE	32 mm		FREQUENCY	60 Hz
	DISCHARGE BORE	25 mm		SPEED	3450 1/min
	LIQUID	WATER		TYPE	Induction Motor
	MAKER	WILO		MAKER	WILO

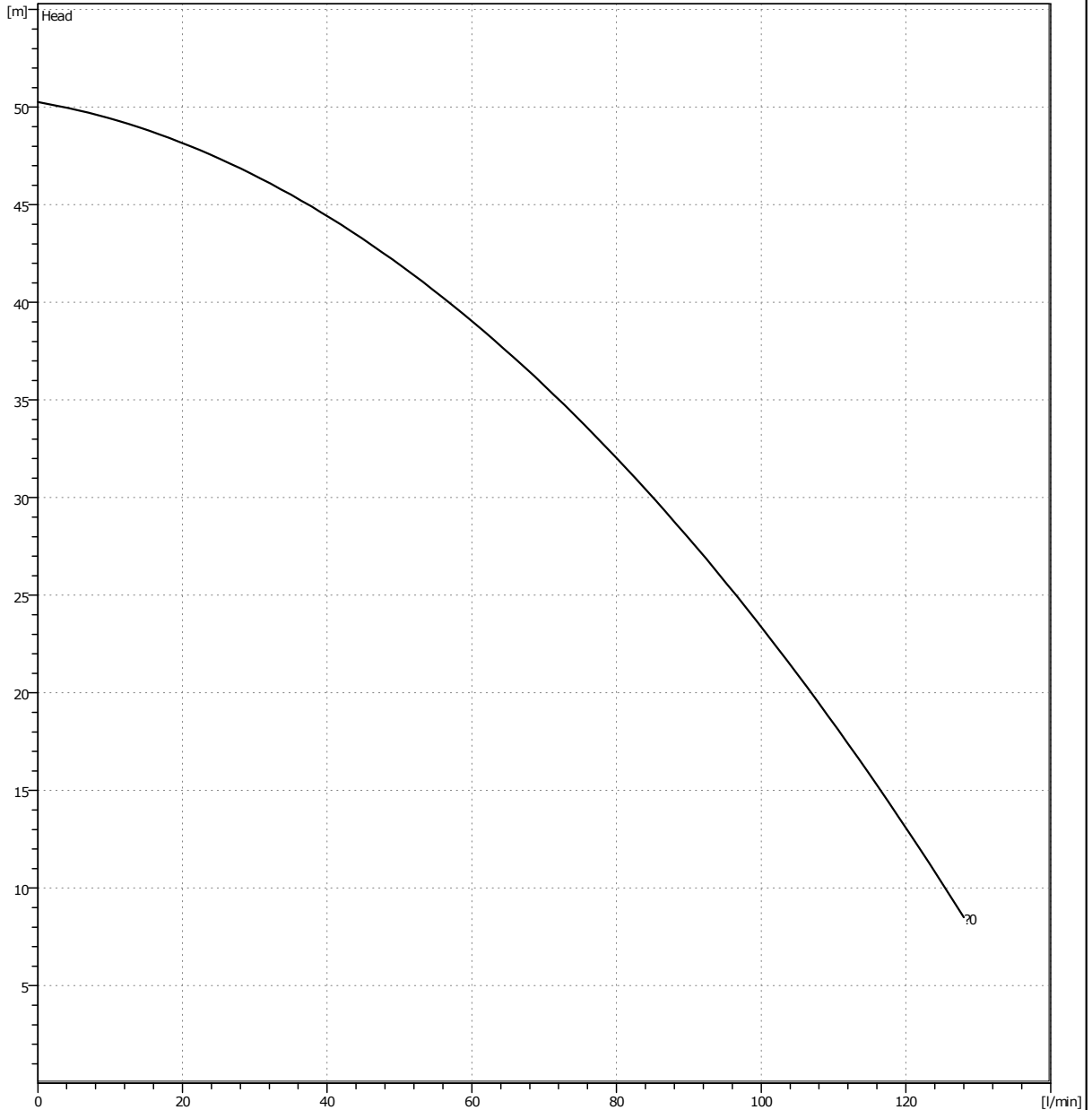

*Performance curve of some models is subject to have 10% deviation.
 *Subject to change without prior notice.

TYPE	Muiti Stage Horizontal
MODEL	PBI-L603MA
SERVICE	

Outline Drawing

Sheet No.	
Customer	
Item No.	
Date	2017-03-28

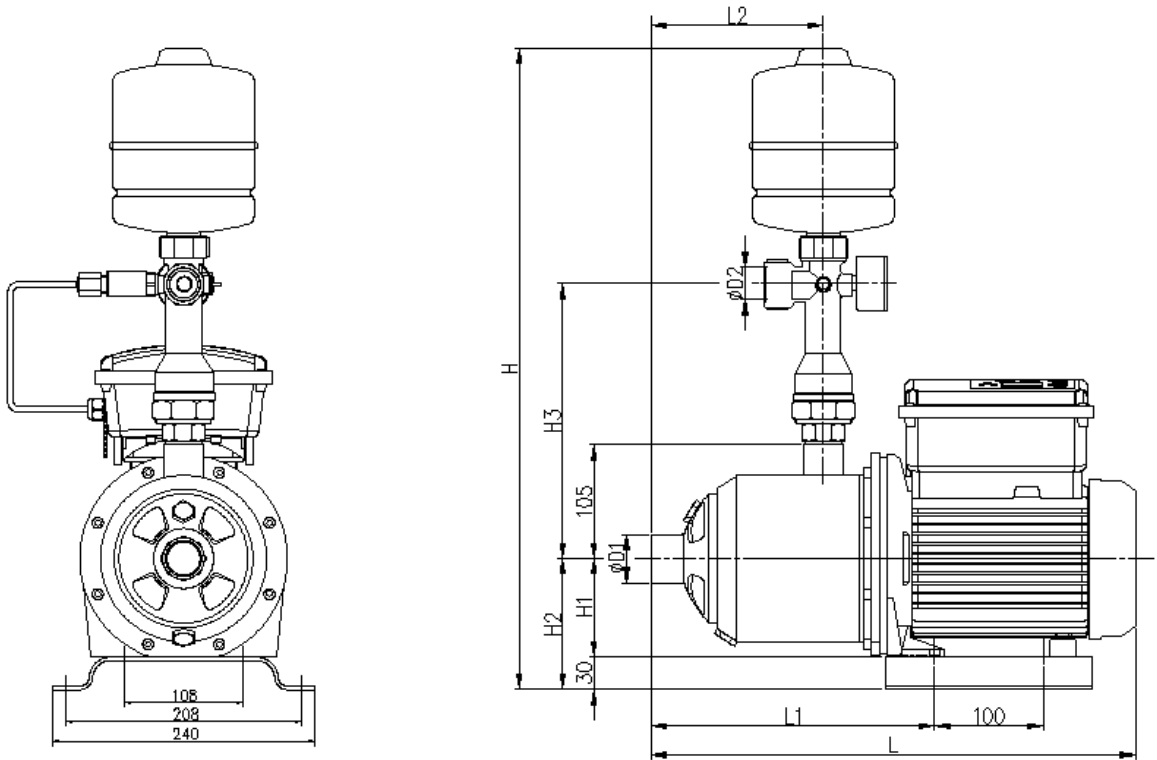

品名	Dimension(mm)										重量 (kg)
	H	H1	H2	H3	L	L1	L2	ΦD1	ΦD2		
PBI-L203MA	580	90	120	380	385	185	109.5	1"	1"	13	
PBI-L205MA	580	90	120	380	425	235	157.5	1"	1"	14	
PBI-L303MA	580	90	120	380	425	235	157.5	1"	1"	10	
PBI-L304MA	580	90	120	380	425	235	157.5	1"	1"	11	
PBI-L402MA	580	90	120	380	385	185	109.5	1 1/4"	1"	13	
PBI-L403MA	580	90	120	380	385	185	109.5	1 1/4"	1"	14	
PBI-L404MA	580	90	120	380	425	235	157.5	1 1/4"	1"	19.5	
PBI-L405MA	580	90	120	380	425	235	157.5	1 1/4"	1"	20	
PBI-L603MA	580	90	120	380	425	235	157.5	1"	1"	11	
PBI-L802MA	580	90	120	385	385	185	109.5	1 1/2"	1 1/4"	18	
PBI-L803MA	580	90	120	385	385	185	109.5	1 1/2"	1 1/4"	19	

TYPE	Multi Stage Horizontal
MODEL	PBI-L603MA
SERVICE	

Sectional Drawing

Sheet No.	
Customer	
Item No.	
Date	2017-03-28

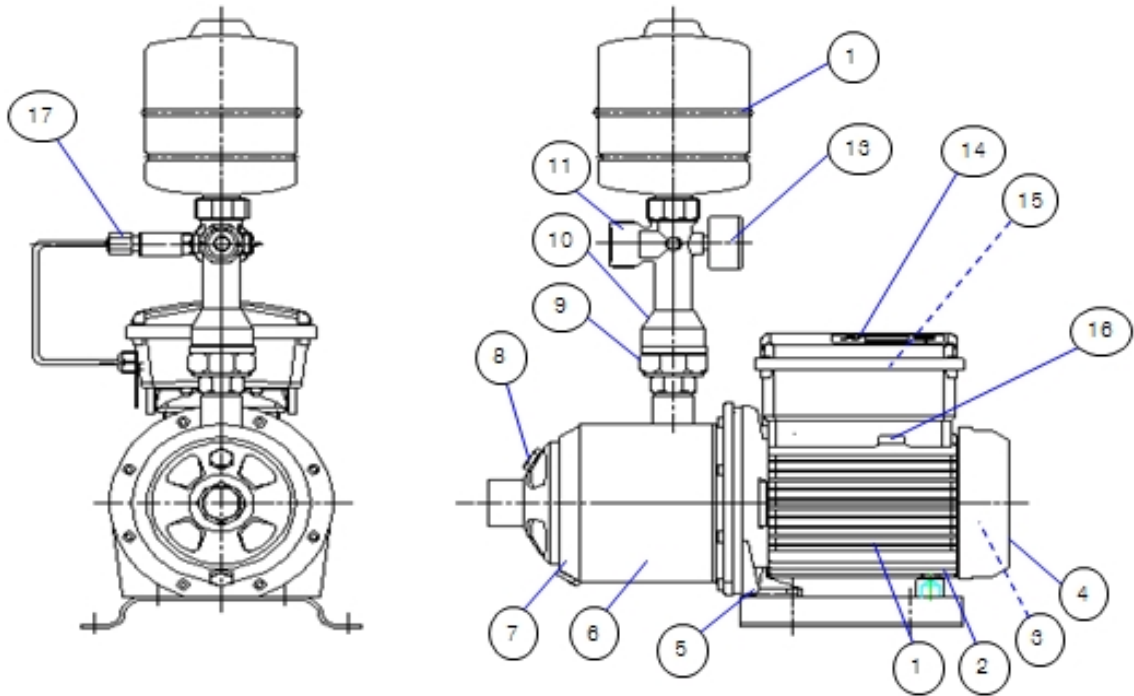

Cls.	Part Name	Specification	Quantity	Remarks
1	Motor Assembly	3phase 220V 60Hz	1	
2	Motor Supporter	ABS(HI-100)	1	
3	Fan	PBT(GP-2200)	1	
4	Fan Cover	SCP or ABS(HI-100)	1	
5	Base Plate	SCP	1	
6	Casing	STS304	1	
7	Drain Plug	STS316L	1	
8	Priming Plug	STS316L	1	
9	Union Assembly	Brass or STS304	1	
10	Check Valve	STS304	1	
11	Cross Nipple	Brass or STS304	1	
12	Pressure Tank	SCP/Rubber	1	
13	Pressure Gauge	16bar	1	
14	Inverter Cover	ABS(AF-305F)	1	
15	Inverter Assembly	-	1	
16	Inverter Base	ABS(AF-305F)	1	
17	Transmitter	16bar	1	

TYPE	Multi Stage Horizontal
MODEL	PBI-L603MA
SERVICE	