

wilo Pump Data Sheet

Sheet No.	
Customer	
Item No.	
Date	2017-03-28

1	Model	PBI-LD402MA		Title			
2	Location			Agent			
3	Service			Plant Name			
4	Quantity	Set(s)		Installation	<input checked="" type="checkbox"/> Indoor	<input type="checkbox"/> Outdoor	
5	OPERATING CONDITION						
6	Liquid	Water		Capacity	200	lpm	
7	Pumping Temp.	0~40		Suct. Head	0	m	
8	S.G	1		Disch. Head	20	m	
9	Vap. Pressure	1kg/cm2A		Total head	20	m	
10	Viscosity	1 cp					
11	PERFORMANCE AND CONSTRUCTIONS					MATERIAL	
12	Horizontal		Efficiency	%		Parts' Name	Symbol
13	No. of Stages	2	Rated Power	0.75kW x 2		Pump	STS304
14	Speed	3450rpm	NPSHre			Bed	SS400
15	Rotation	CCW (view from drive end)			Valve & etc.	STS304	
16	Bore	Size(Dia)	Rating	Face	Position	Manifold	STS304
17	Suction	50 mm	10K		Side		
18	Discharge	50 mm	10K		Top		
19	Impeller Type	Closed	Single suction		HYDROSTATIC		
20	Flow Direction	Radial			Casing	10 kgf/cm2	3 min
21	Shaft Seal	M/Seal	Shaft Sleeve	No			
22	Mounting	Bracket			TESTING		
23	Lubrication	<input checked="" type="checkbox"/> Grease	<input type="checkbox"/> Oil Bath		Items	(Witness)	
24	Cooling	<input type="checkbox"/> Stuff.Box	<input type="checkbox"/> B/R Housing	<input checked="" type="checkbox"/> No Cooling	Run Perform.	<input checked="" type="checkbox"/> Yes <input type="checkbox"/> No	<input type="checkbox"/> Yes <input checked="" type="checkbox"/> No
25	Pump Side	6302ZZ	Fan Side	6201ZZ	Hydrostatic	<input checked="" type="checkbox"/> Yes <input type="checkbox"/> No	<input type="checkbox"/> Yes <input checked="" type="checkbox"/> No
26	DRIVER SPECIFICATION					SPARE PARTS	
27	Maker	WILO	Phase / V / Hz	1 ~ 220V ~ 60Hz			Set(s)
28	Type	Induction Motor	Furnished by	<input checked="" type="checkbox"/> WILO	<input type="checkbox"/> Customer		Set(s)
29	Power	0.75kW x 2	Mounted by	<input checked="" type="checkbox"/> WILO	<input type="checkbox"/> Customer		Set(s)
30	Pole & Speed	2p 3450rpm					Set(s)
31	Insulation	F					Set(s)
32	ACCESSORIES(<input checked="" type="checkbox"/>Supplied : WILO)						Set(s)
33	<input checked="" type="checkbox"/> Common Base						Set(s)
34	<input type="checkbox"/> Foundation Bolts & Nuts						Set(s)
35	<input type="checkbox"/> Coupling	No		<input type="checkbox"/> Coupling Guard			Set(s)
36	<input type="checkbox"/> Pressure Gauge						Set(s)
37	<input type="checkbox"/> Collar or Plug for Drain & Air vent.						Set(s)
38	<input type="checkbox"/> Seal Flushing						Set(s)
39	M/Seal	Maker	Burgmann	Model & Size	Ø14		Set(s)
40		Type	MG12/14	Cooler	<input type="checkbox"/> Yes <input checked="" type="checkbox"/> No		Set(s)
41							Set(s)
42	<input type="checkbox"/> Companion Flanges					Weight	
43	<input type="checkbox"/> Special Tool						
44							
45						Total Wt.	47 kg

Estimated Performance Curve

Sheet No.	
Customer	
Item No.	
Date	2017-03-28

SPECIFICATION

PUMP	Capacity	200 lpm at m	MOTOR	OUTPUT	0.75kW x 2
	Total Head	20 m		VOLTAGE	220V
	SUCTION BORE	50 mm		FREQUENCY	60 Hz
	DISCHARGE BORE	50 mm		SPEED	3450 1/min
	LIQUID	WATER		TYPE	Induction Motor
	MAKER	WILO		MAKER	WILO

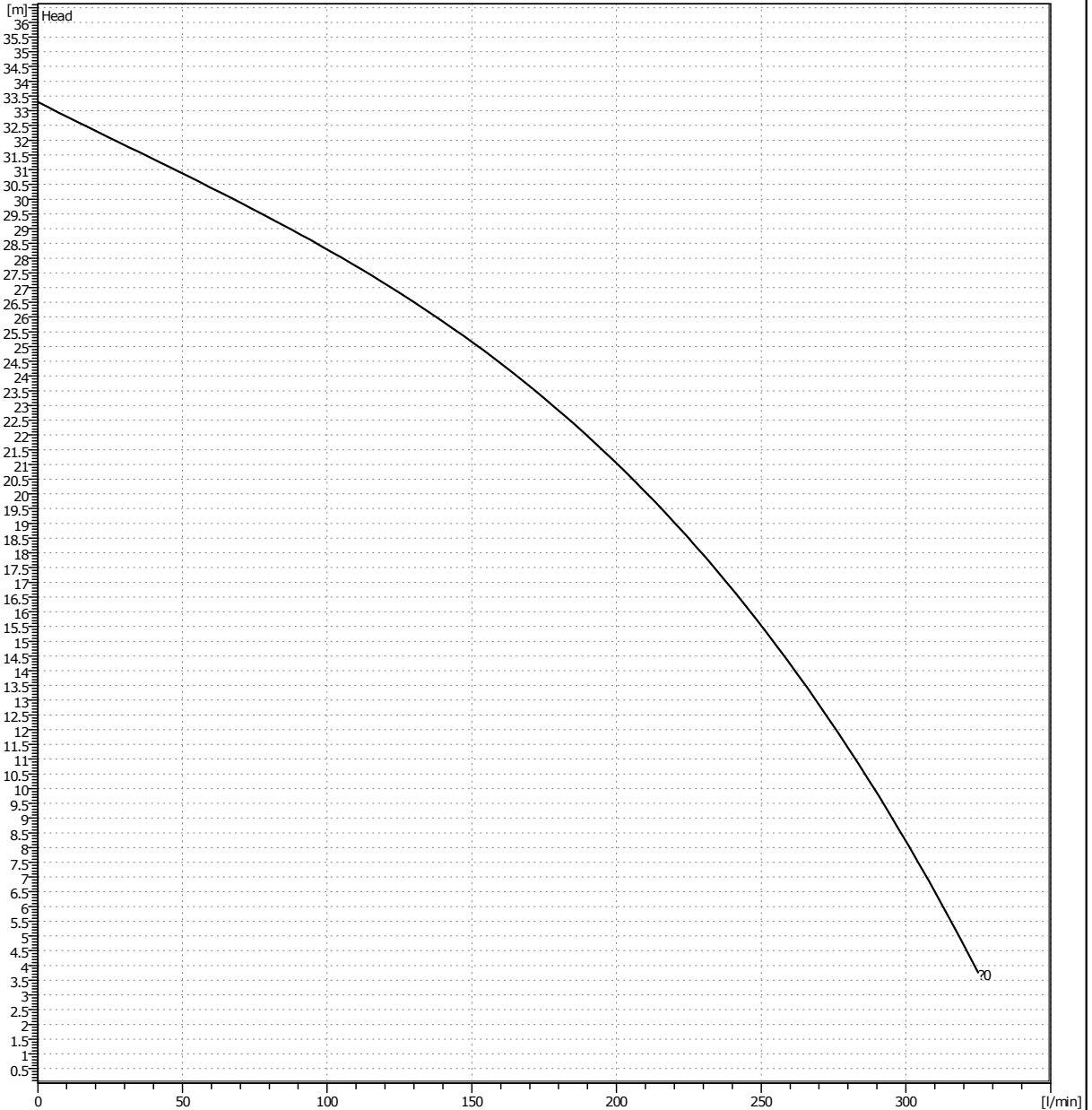

*Performance curve of some models is subject to have 10% deviation.
 *Subject to change without prior notice.

TYPE	Muiti Stage Horizontal
MODEL	PBI-LD402MA
SERVICE	

Outline Drawing

Sheet No.	
Customer	
Item No.	
Date	2017-03-28

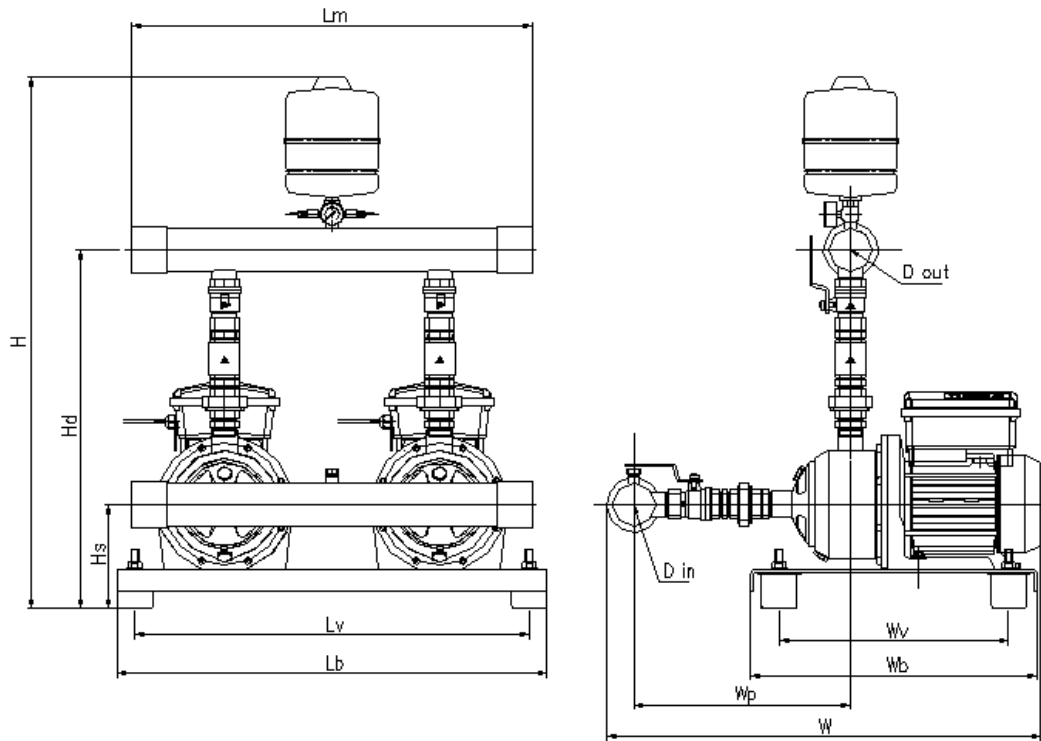

Model Name	Model Name												중량(kg)
	H	Hs	Hd	Lm	Lv	Lb	W	Wp	Wv	Wb	Din	Dout	
PBI-LD402MA	870	140	530	560	550	600	655	360	320	400	50A	50A	47
PBI-LD403MA	870	140	530	560	550	600	655	360	320	400	50A	50A	49
PBI-LD404MA	870	140	530	560	550	600	655	360	320	400	50A	50A	51
PBI-LD405MA	870	140	530	560	550	600	655	360	320	400	50A	50A	54
PBI-LD802MA	870	140	560	560	550	600	725	380	320	400	65A	65A	64
PBI-LD803MA	870	140	560	560	550	600	725	380	320	400	65A	65A	67

TYPE	Muiti Stage Horizontal
MODEL	PBI-LD402MA
SERVICE	

Sectional Drawing

Sheet No.	
Customer	
Item No.	
Date	2017-03-28

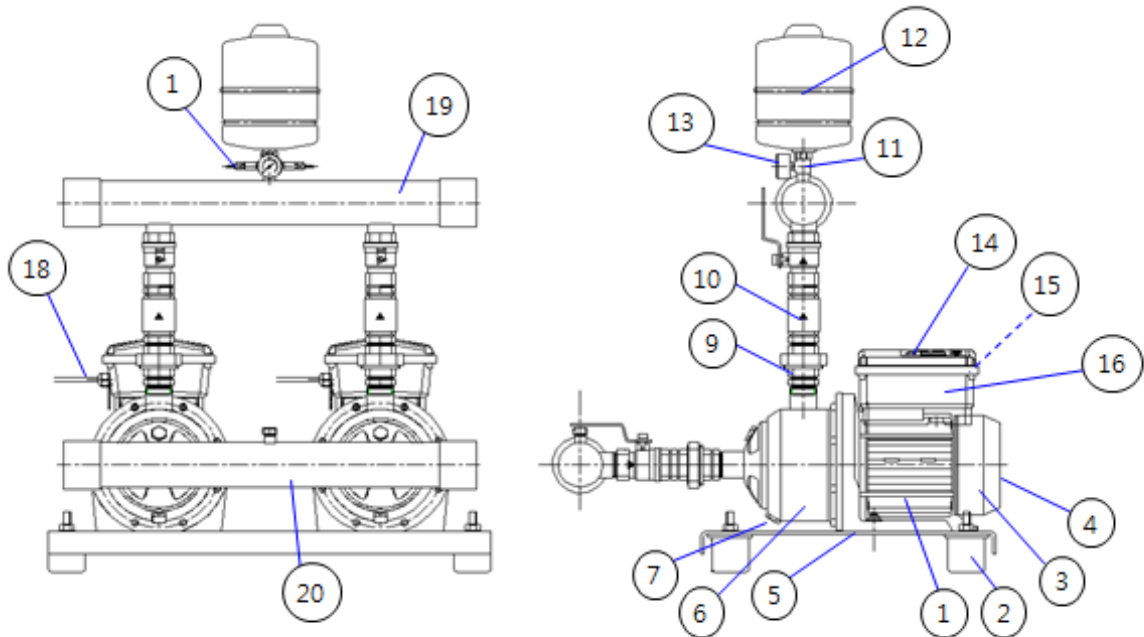

Cls.	Part Name	Specification	Quantity	Remarks
1	Motor Assembly	3phase 220V 60Hz	1	
2	Vibration protector	ABS(HI-100)	1	
3	Fan	PBT(GP-2200)	1	
4	Fan Cover	SCP or ABS(HI-100)	1	
5	Base Plate	SCP	1	
6	Casing	STS304	1	
7	Drain Plug	STS316L	1	
8	Priming Plug	STS316L	1	
9	Union Assembly	STS304	1	
10	Check Valve	STS304	1	
11	3Way Nipple	STS304	1	
12	Pressure Tank	SCP/Rubber	1	
13	Pressure Gauge	15bar	1	
14	Inverter Cover	ABS	1	
15	Inverter Assembly	1phase 220V 60Hz	1	
16	Inverter Base	ABS	1	
17	Transmitter	16bar	1	
18	Power Cord	PNCT 3C	1	
19	Discharge manifold	STS304	1	
20	Suction manifold	STS304	1	

TYPE	Muiti Stage Horizontal
MODEL	PBI-LD402MA
SERVICE	