

# wilo Pump Data Sheet

Sheet No.	
Customer	
Item No.	
Date	2017-03-28

1	<b>Model</b>	PBI-LD403MA		Title	
2	Location			Agent	
3	Service			Plant Name	
4	Quantity	Set(s)	Installation	<input checked="" type="checkbox"/> Indoor	<input type="checkbox"/> Outdoor
5	<b>OPERATING CONDITION</b>				
6	Liquid	Water		Capacity	180 lpm
7	Pumping Temp.	0~40		Suct. Head	0 m
8	S.G	1		Disch. Head	35 m
9	Vap. Pressure	1kg/cm2A		Total head	35 m
10	Viscosity	1 cp			
11	<b>PERFORMANCE AND CONSTRUCTIONS</b>			<b>MATERIAL</b>	
12	Horizontal	Efficiency	%		Parts' Name
13	No. of Stages	3	Rated Power	1.1kW x 2	
14	Speed	3450rpm	NPSHre	Bed	
15	Rotation	CCW (view from drive end)			Valve & etc.
16	<b>Bore</b>	Size(Dia)	Rating	Face	Position
17	Suction	50 mm	10K	Side	
18	Discharge	50 mm	10K	Top	
19	Impeller Type	Closed	Single suction		<b>HYDROSTATIC</b>
20	Flow Direction	Radial		Casing	10 kgf/cm2
21	Shaft Seal	M/Seal	Shaft Sleeve	No	3 min
22	Mounting	Bracket			<b>TESTING</b>
23	Lubrication	<input checked="" type="checkbox"/> Grease	<input type="checkbox"/> Oil Bath		Items (Witness)
24	Cooling	<input type="checkbox"/> Stuff.Box	<input type="checkbox"/> B/R Housing	<input checked="" type="checkbox"/> No Cooling	Run Perform. <input checked="" type="checkbox"/> Yes <input type="checkbox"/> No <input type="checkbox"/> Yes <input checked="" type="checkbox"/> No
25	Pump Side	6304ZZ	Fan Side	6202ZZ	Hydrostatic <input checked="" type="checkbox"/> Yes <input type="checkbox"/> No <input type="checkbox"/> Yes <input checked="" type="checkbox"/> No
26	<b>DRIVER SPECIFICATION</b>			<b>SPARE PARTS</b>	
27	Maker	WILO	Phase / V / Hz	1 ~ 220V ~ 60Hz	
28	Type	Induction Motor	Furnished by	<input checked="" type="checkbox"/> WILO <input type="checkbox"/> Customer	Set(s)
29	Power	1.1kW x 2	Mounted by	<input checked="" type="checkbox"/> WILO <input type="checkbox"/> Customer	Set(s)
30	Pole & Speed	2p 3450rpm		Set(s)	
31	Insulation	F		Set(s)	
32	<b>ACCESSORIES( <input checked="" type="checkbox"/>Supplied : WILO)</b>			Set(s)	
33	<input checked="" type="checkbox"/> Common Base			Set(s)	
34	<input type="checkbox"/> Foundation Bolts & Nuts			Set(s)	
35	<input type="checkbox"/> Coupling	No		<input type="checkbox"/> Coupling Guard	Set(s)
36	<input type="checkbox"/> Pressure Gauge			Set(s)	
37	<input type="checkbox"/> Collar or Plug for Drain & Air vent.			Set(s)	
38	<input type="checkbox"/> Seal Flushing			Set(s)	
39	M/Seal	Maker	Burgmann	Model & Size	Ø14
40		Type	MG12/14	Cooler	<input type="checkbox"/> Yes <input checked="" type="checkbox"/> No
41				Set(s)	
42	<input type="checkbox"/> Companion Flanges			<b>Weight</b>	
43	<input type="checkbox"/> Special Tool				
44					
45				Total Wt.	49 kg

# Estimated Performance Curve

Sheet No.	
Customer	
Item No.	
Date	2017-03-28

## SPECIFICATION

<b>PUMP</b>	Capacity	180 lpm at	m	<b>MOTOR</b>	OUTPUT	1.1kW x 2
	Total Head	35	m		VOLTAGE	220V
	SUCTION BORE	50	mm		FREQUENCY	60 Hz
	DISCHARGE BORE	50	mm		SPEED	3450 1/min
	LIQUID	WATER			TYPE	Induction Motor
	MAKER	WILO			MAKER	WILO

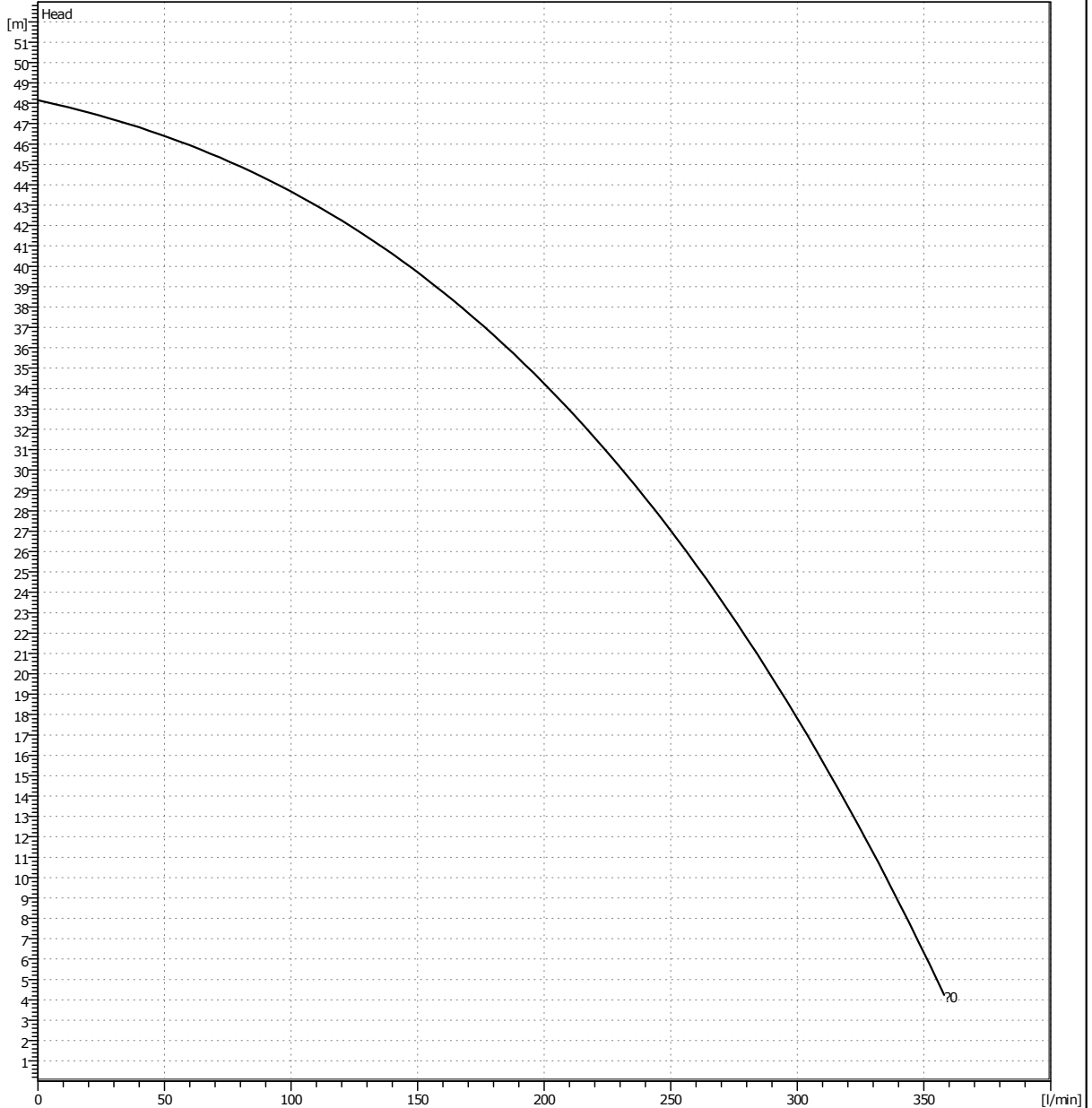

\*Performance curve of some models is subject to have 10% deviation.

\*Subject to change without prior notice.

TYPE	Muiti Stage Horizontal
MODEL	PBI-LD403MA
SERVICE	

# Outline Drawing

Sheet No.	
Customer	
Item No.	
Date	2017-03-28

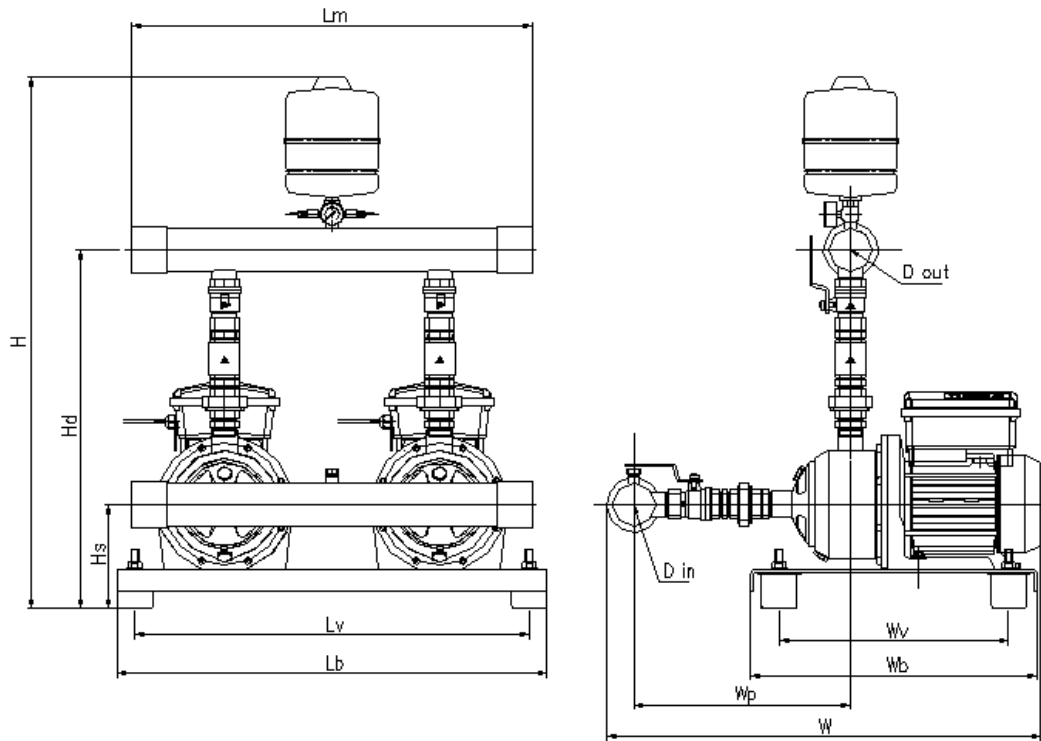

Model Name	Model Name												중량(kg)
	H	Hs	Hd	Lm	Lv	Lb	W	Wp	Wv	Wb	Din	Dout	
PBI-LD402MA	870	140	530	560	550	600	655	360	320	400	50A	50A	47
PBI-LD403MA	870	140	530	560	550	600	655	360	320	400	50A	50A	49
PBI-LD404MA	870	140	530	560	550	600	655	360	320	400	50A	50A	51
PBI-LD405MA	870	140	530	560	550	600	655	360	320	400	50A	50A	54
PBI-LD802MA	870	140	560	560	550	600	725	380	320	400	65A	65A	64
PBI-LD803MA	870	140	560	560	550	600	725	380	320	400	65A	65A	67

TYPE	Muiti Stage Horizontal
MODEL	PBI-LD403MA
SERVICE	

# Sectional Drawing

Sheet No.	
Customer	
Item No.	
Date	2017-03-28

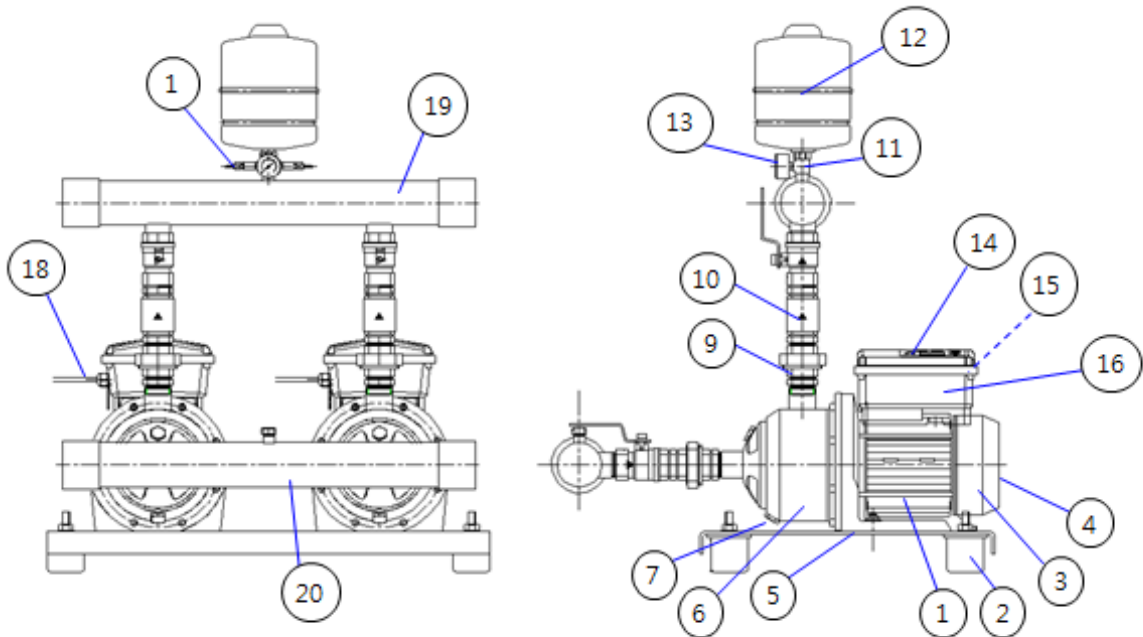

Cls.	Part Name	Specification	Quantity	Remarks
1	Motor Assembly	3phase 220V 60Hz	1	
2	Vibration protector	ABS(HI-100)	1	
3	Fan	PBT(GP-2200)	1	
4	Fan Cover	SCP or ABS(HI-100)	1	
5	Base Plate	SCP	1	
6	Casing	STS304	1	
7	Drain Plug	STS316L	1	
8	Priming Plug	STS316L	1	
9	Union Assembly	STS304	1	
10	Check Valve	STS304	1	
11	3Way Nipple	STS304	1	
12	Pressure Tank	SCP/Rubber	1	
13	Pressure Gauge	15bar	1	
14	Inverter Cover	ABS	1	
15	Inverter Assembly	1phase 220V 60Hz	1	
16	Inverter Base	ABS	1	
17	Transmitter	16bar	1	
18	Power Cord	PNCT 3C	1	
19	Discharge manifold	STS304	1	
20	Suction manifold	STS304	1	

TYPE	Muiti Stage Horizontal
MODEL	PBI-LD403MA
SERVICE	