

Estimated Performance Curve

Sheet No.	
Customer	
Item No.	
Date	2017-03-07

SPECIFICATION

PUMP	Capacity	400 lpm at 20 m	MOTOR	OUTPUT	2.2KW
	Total Head	20 m		VOLTAGE	220/380V
	SUCTION BORE	50 mm		FREQUENCY	60Hz
	DISCHARGE BORE	40 mm		SPEED	3450rpm
	LIQUID	WATER		TYPE	TEFC
	MAKER	WILO		MAKER	WILO

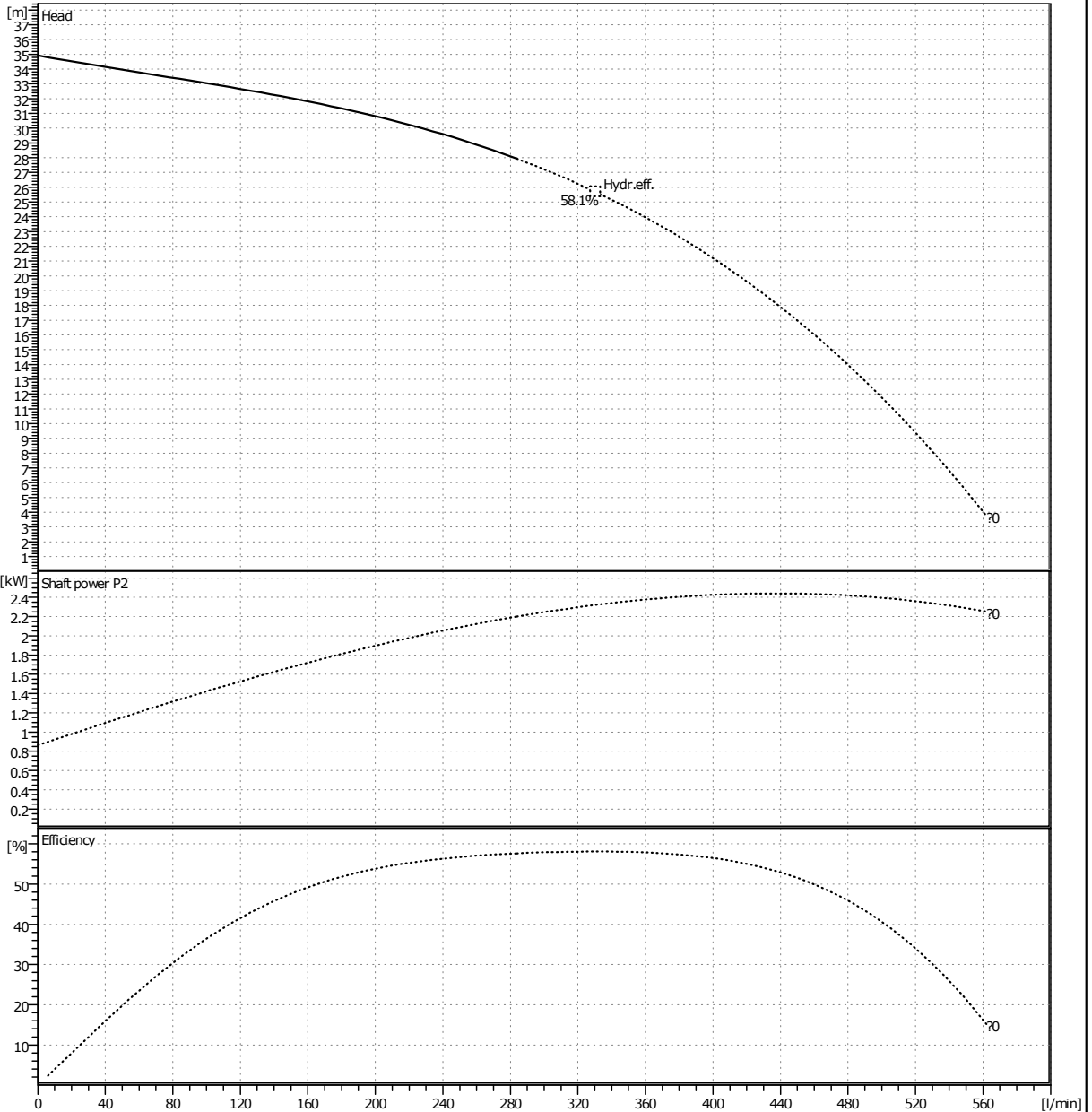

* Performance curve of some models is subject to have 10% deviation.

* Subject to change without prior notice.

TYPE	Horizontal Multi-stage
MODEL	MHI-1602i
SERVICE	

Outline Drawing

Sheet No.	
Customer	
Item No.	
Date	2017-03-07

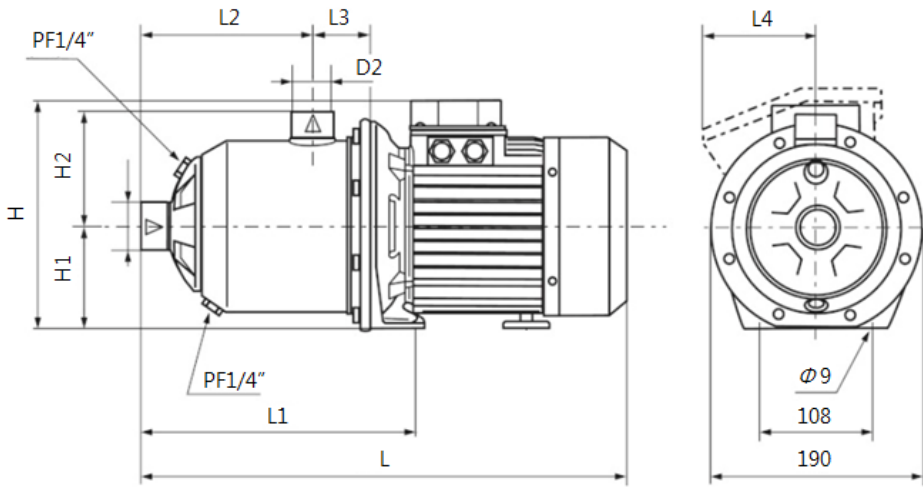

단위 : mm

Model	Power Source	H	H1	H2	L	L1	L2	L3	L4	D1	D2
MHI 1602	I (3~,220/380, 60Hz)	237	100	104	443	236	138	51	-	50	40
	N (3~,440V,60Hz)										

TYPE	Horizontal Multi-stage
MODEL	MHI-1602i
SERVICE	