

# Estimated Performance Curve

Sheet No.	
Customer	
Item No.	
Date	2017-03-07

## SPECIFICATION

<b>PUMP</b>	Capacity	230 lpm at 20 m	<b>MOTOR</b>	OUTPUT	1.5KW
	Total Head	20 m		VOLTAGE	220/380V
	SUCTION BORE	40 mm		FREQUENCY	60Hz
	DISCHARGE BORE	30 mm		SPEED	3450rpm
	LIQUID	WATER		TYPE	TEFC
	MAKER	WILO		MAKER	WILO

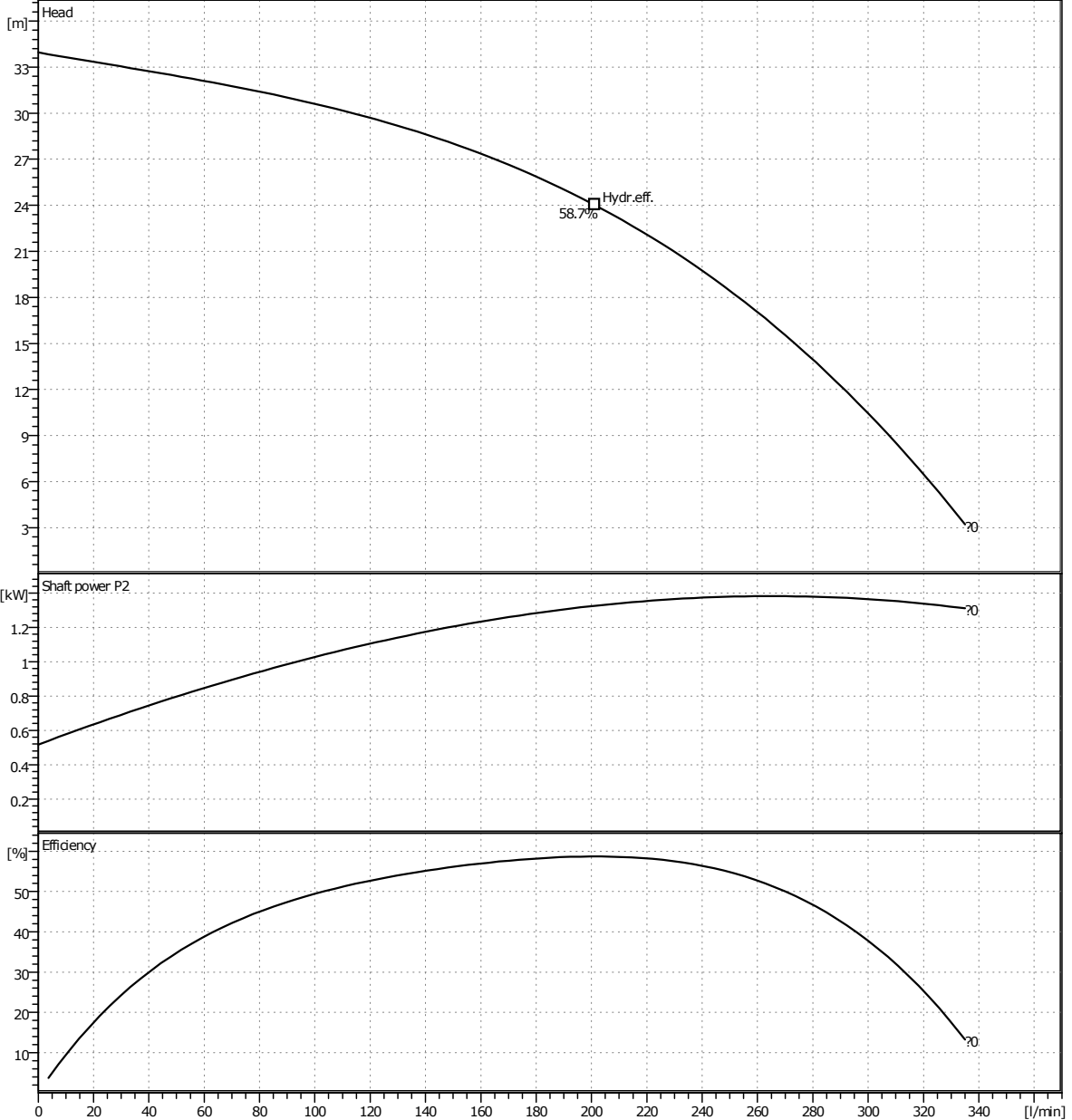

\* Performance curve of some models is subject to have 10% deviation.

\* Subject to change without prior notice.

TYPE	Horizontal Multi-stage
MODEL	MHI-802i
SERVICE	

# Outline Drawing

Sheet No.	
Customer	
Item No.	
Date	2017-03-07

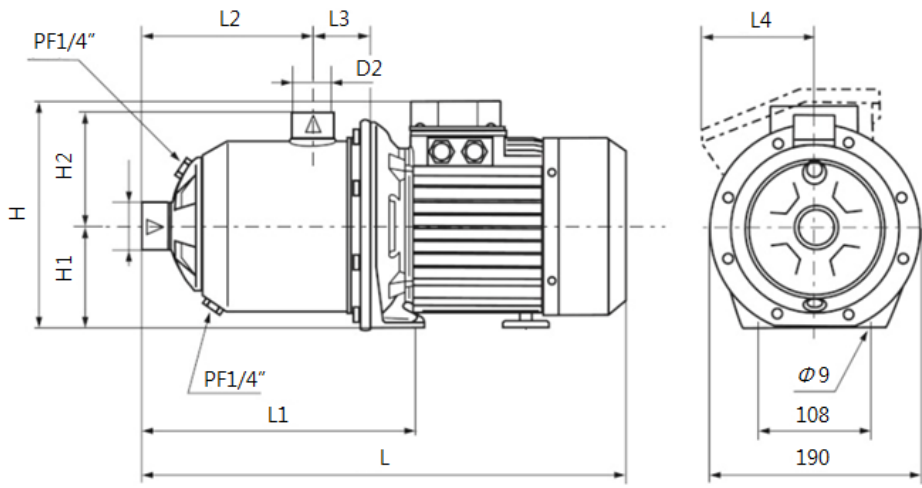

단위 : mm

Model	Power Source	H	H1	H2	L	L1	L2	L3	L4	D1	D2
MHI 802	M (1~, 220V, 60Hz)	228	90	104	392	216	121.5	51	106	40	30
MHI 802	I (3~, 220/380, 60Hz)	223	90	104	392	216	121.5	51	-	40	30
MHI 803		223	90	104	392	216	121.5	51	-	40	30
MHI 804	N (3~, 440V, 60Hz)	237	100	104	483	276	181.5	51	-	40	30
MHI 805		237	100	104	483	276	181.5	51	-	40	30

TYPE	Horizontal Multi-stage
MODEL	MHI-802i
SERVICE	