

wilo Pump Data Sheet

Sheet No.	
Customer	
Item No.	
Date	2017-07-04

1	MODEL	PD-H753MA			Title				
2	OPTION MODEL				Quantity		Set(s)		
3	Location				Agent				
4	Service				Plant Name				
5	OPERATING CONDITION								
6	Liquid Pumped	Drainage Water			Capacity	120			
7	Pumping Temp.	Winter : -5 C			Dis. Press				
8		Summer : 40 C			Total Head	20			
9	Specific Gravity	1 kgf/cm ² A			Total Head at zero point		28 m		
10	Viscosity	5 cP			Liquid pH		6.5~9 pH		
11	PERFORMANCE AND CONSTRUCTION					MATERIAL			
12	Axis Position	Vertical		C.W.L	280 mm	Part Name	Symbol		
13	Number of Stages	1		EFF. Expected	%	Impeller	GC200		
14	Speed	3450 rpm		Rated Power	950W	Shaft	SM20C+STS410		
15	Rotation Viewde From Driver	CW			Casing	GC150			
16	BORE	Size(Dia)	Rating	Facing	Position	Frame	GC150		
17		Suction	-	-	-	-	Head Cover	GC150	
18		Discharge	50 mm	-	-	Side	Cable	PNCT	
19	Impeller Type	Semi Open			Single Suction	Sleeve	STS316		
20	Flow Direction	Radial		Oil Seal	Yes				
21	Shaft Seal	M/Seal		Shaft Sleeve	Yes				
22	Adpater	<input type="checkbox"/> Yes	<input checked="" type="checkbox"/> No	Adapter Model	N/A				
23	Discharge Type	FLANGE & HOSE COUPLING							
24	Struction of Inlet	Strainer				HYDROSTATIC			
25	Struction of Outlet	FLANGE & HOSE COUPLING				Casing	kgf/cm ²	min	
26	Bearings	Upper : 6202zz		Lower : 6203zz		Frame	kgf/cm ²	min	
27	MOTOR SPECIFICATION					TESTING			
28	Motor	Maker	WILO			(Items)		(Witness)	
29	Type	Induction Motor(Submersible Type)				Run Perform	<input checked="" type="checkbox"/> Yes <input type="checkbox"/> No	<input type="checkbox"/> Yes <input checked="" type="checkbox"/> No	
30	Starting Method	LINE	Power Supply	1~ 220V		Hydrostatic (Air Press.)	<input checked="" type="checkbox"/> Yes <input type="checkbox"/> No	<input type="checkbox"/> Yes <input checked="" type="checkbox"/> No	
31	Pole & Speed	3450 1/min	Frequency	60 Hz		SPARE PART			
32	Output	950W	Insulation	B	Amperage	7A	Impeller	Set(s)	
33	Protector	<input type="checkbox"/> Over Load Protector(O.L.P)		<input checked="" type="checkbox"/> Thermal Protector(T.P)		Shaft	Set(s)		
34	SEAL PART					Sleeve	Set(s)		
35	Mechanical Seal	Maker	NEK	Size	15	Bearing	Set(s)		
36		Type	Double	Cooler Type	T-#32	Casing	Set(s)		
37		Cooler	Yes	Cooler Quantity	200cc	M/Seal	Set(s)		
38	ACCESSORY					Name Plate	Set(s)		
39	<input checked="" type="checkbox"/> Companion Flanges						Set(s)		
40	<input type="checkbox"/> Chain						Set(s)		
41	<input checked="" type="checkbox"/> Hose Coupling						Set(s)		
42	<input type="checkbox"/> Foundation Bolts & Nuts					WEIGHT			
43	<input type="checkbox"/> Guide Pipe					Pump	25.5 kg		
44	<input type="checkbox"/> Special Tool					Adapter	-		
45	<input type="checkbox"/> Spare Parts					Total Wt.	25.5 kg		

Remark
* Protector does not supply in 50Hz.

* The above data can be changed without prior notice.

Estimated Performance Curve

Sheet No.	
Customer	
Item No.	
Date	2017-07-04

SPECIFICATION			
PUMP	CAPACITY	0 l/min	MOTOR
	TOTAL HEAD	0 m	
	SUCTION BORE		
	DISCHARGE BORE	50 mm	
	LIQUID	WATER	
	MAKER	WILO	
	OUTPUT	950W	
VOLTAGE	220V		
FREQUENCY	60 Hz		
SPEED	3450 1/min		
TYPE	Induction Motor		
MAKER	WILO		

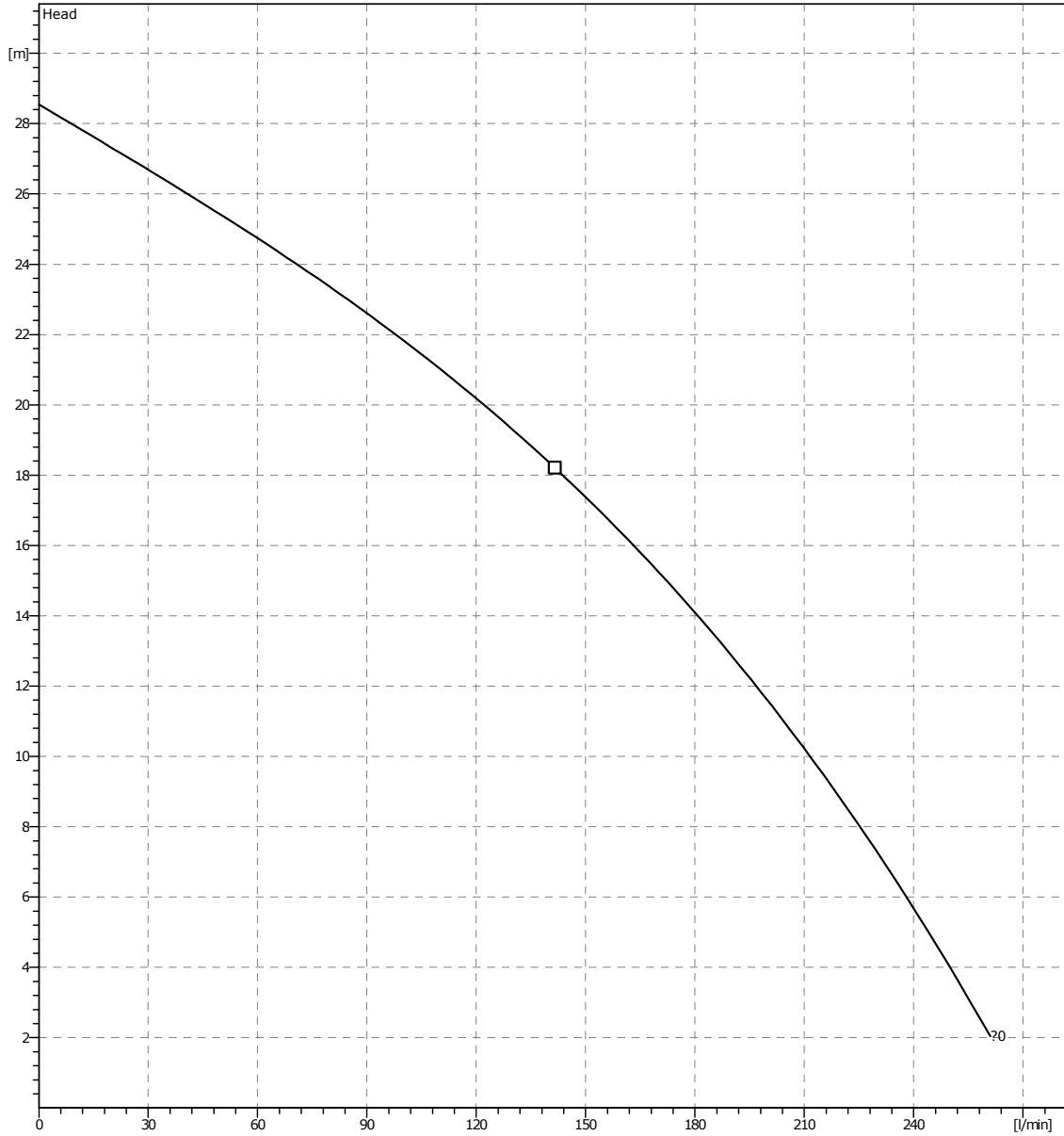

*Pump test acceptance grade in accordance with ISO 9906:2012, Grade 2B.

*Subject to change without prior notice.

TYPE	Submersible, General Drainage
MODEL	PD-H753MA
SERVICE	

Outline Drawing

Sheet No.	
Customer	
Item No.	
Date	2017-07-04

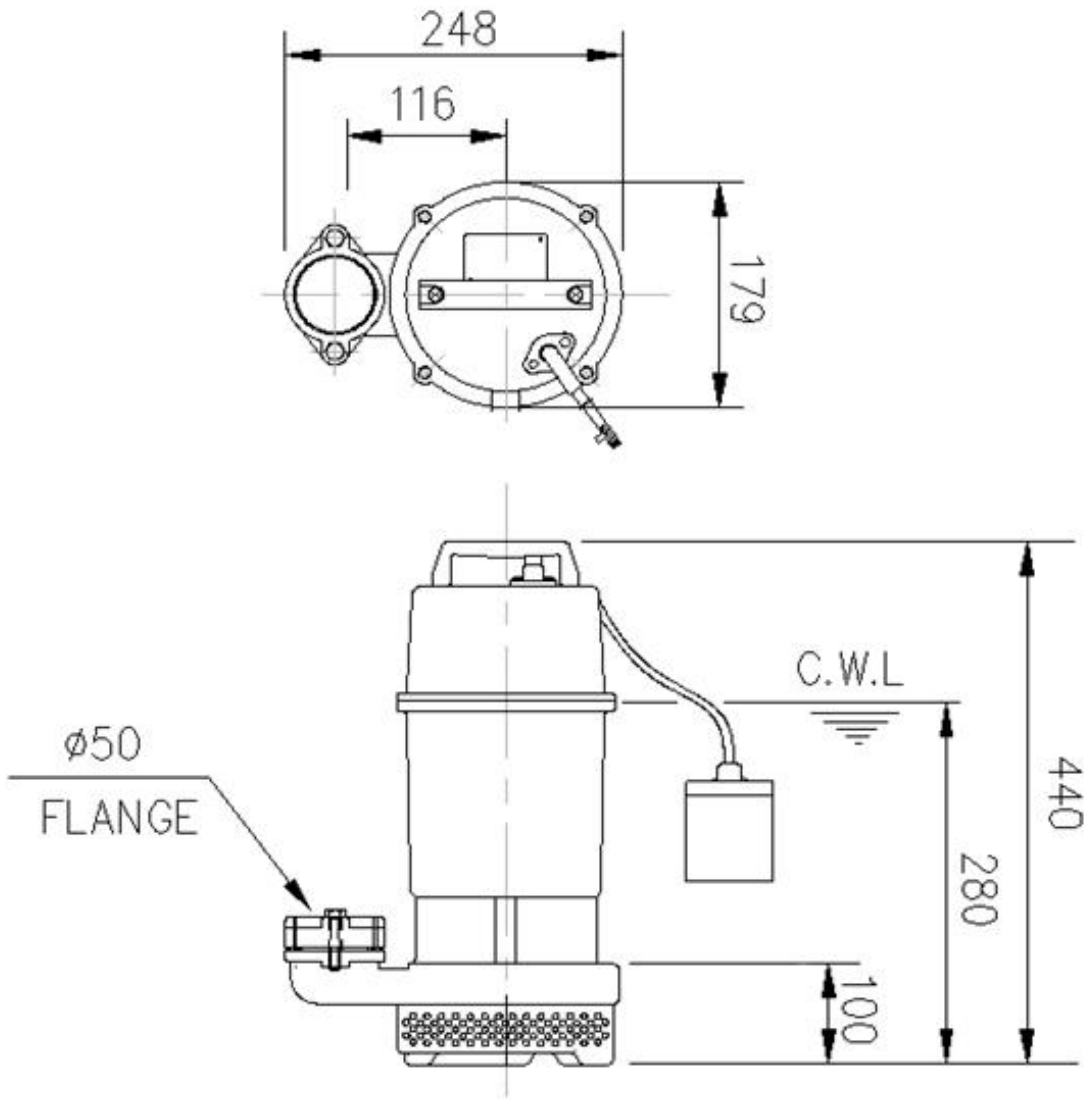

C.W.L : Continuous Running
Water Level

TYPE	Submersible,General Drainage
MODEL	PD-H753MA
SERVICE	

Sectional Drawing

Sheet No.	
Customer	
Item No.	
Date	2017-07-04

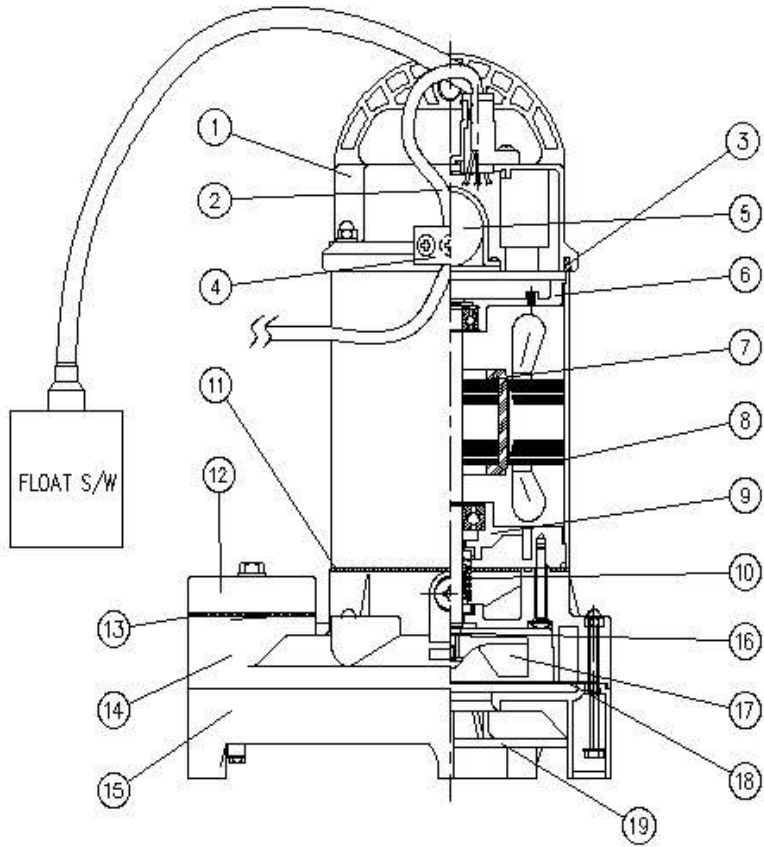

NO.	PARTS NAME	MATERIALS			Q'ty (EA)	NO.	PARTS NAME	MATERIALS			Q'ty (EA)
		KS	AISI	DIN				KS	AISI	DIN	
1	HEAD COVER	PP	-	-	1	11	GASKET	NBR610	-	-	1
2	CABLE ASS'Y	-	-	-	1	12	FLANGE	PBT	-	-	1
3	GASKET	NBR610	-	-	1	13	GASKET	NR607	-	-	1
4	HOLDER CABLE	PP	-	-	1	14	CASING COVER	PP	-	-	1
5	CAPACITOR	-	-	-	1	15	CASING	PP	-	-	1
6	ROTOR ASS'Y	-	-	-	1	16	CONICAL WASHER	STS304	304	X50CrMn89	1
7	FRAME ASS'Y	STS304	304	X5CrMn89	1	17	IMPELLER	Brass	-	-	1
8	END BRACKET(B)	A#	-	-	1	18	GASKET	NBR710	-	-	1
9	END BRACKET(A)	A#	-	-	1	19	STRAINER	PP	-	-	1
10	MECHANICAL SEAL	SiC+SiC	-	-	1	*	BOLTS,NUTS	STS304	304	X50CrMn89	-

TYPE	Submersible,General Drainage
MODEL	PD-H753MA
SERVICE	